



# INSTALLATION / MAINTENANCE / OWNERS MANUAL

CAE-PV10PX – 2 POST OVERHEAD LIFT

Capacity: 10,000lbs.



# CONTENTS

Product Features and Specifications .....	3
Installation Requirement .....	5
Installation Steps .....	7
Exploded View.....	30
Test Run.....	34
Operation Instruction.....	36
Maintenance.....	37
Trouble Shooting.....	38
Preventive Maintenance Schedule .....	39
Warranty.....	41

## I. PRODUCT FEATURES AND SPECIFICATIONS

### CLEAR-FLOOR DIRECT-DRIVE MODEL FEATURES

#### Model PV10 (See Fig. 1)

- Direct-drive design minimizes the lift wear parts and breakdown ratio.
- Dual hydraulic cylinders, designed and made to high standards, utilizing imported oil seal in cylinder.
- Self-lubricating UHMW Polyethylene slide blocks and bronze bushings.
- Single-point safety release with dual safety design.
- Clear-floor design provides unobstructed floor use.
- Overhead safety shut-off device prevents vehicle damage.

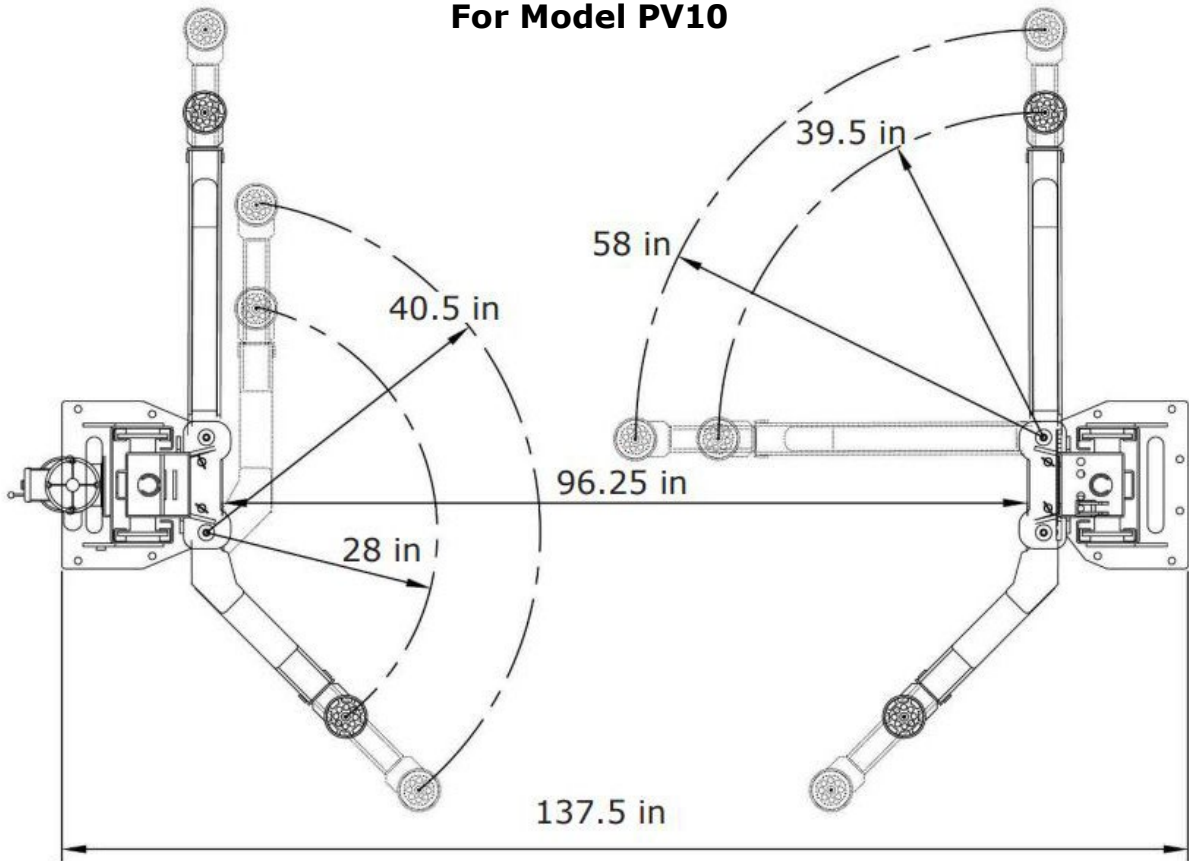


**Fig. 1**

### MODEL PV10 SPECIFICATIONS

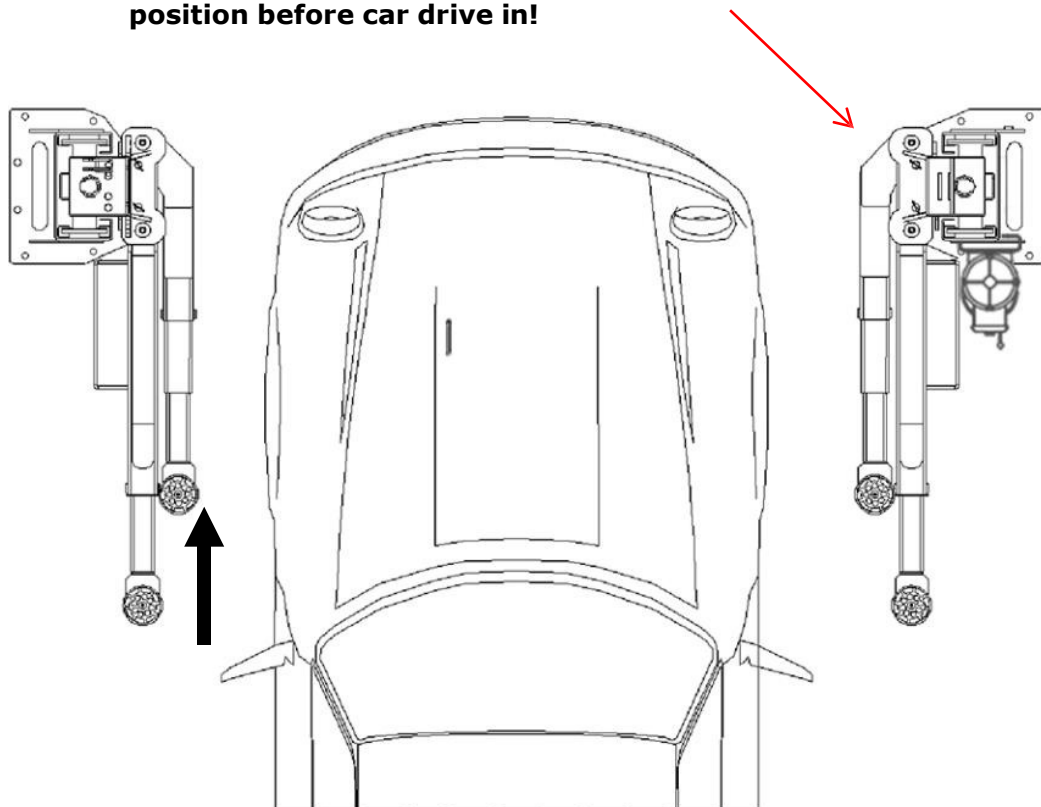
Model	Style	Lifting Capacity	Lifting Time	Lifting Height	Overall Height	Overall Width	Width Between Columns	Minimum Pad Height	Motor
PV10	Clear-floor Direct-drive	5.0 T/ 10000 LBS	55S	72 ½" – 83 1/8"	143 1/8" – 147"	137 ½"	110 ¼"	4 ½" – 13 ½"	2.0HP

**Arm Swings View  
For Model PV10**



**Fig. 2**

**Attention! Please make sure place the arms in correct position before car drive in!**



**Fig. 3**

## II. INSTALLATION REQUIREMENT

### A. TOOLS REQUIRED

- ✓ Rotary Hammer Drill ( $\Phi 3/4$ " Bit)



- ✓ Hammer



- ✓ Level Bar



- ✓ Crescent Wrench (12")



- ✓ Ratchet With Socket (28#)



- ✓ Wrench set

(10#, 13#, 14#, 15#, 17#, 19#, 24#, 27#, 30#)



- ✓ Carpenter's Chalk



- ✓ Screw Sets



- ✓ Tape Measure (25 FT)



- ✓ Pliers



- ✓ Allen Head (3mm, 5mm, 8mm)



- ✓ Vise Grips



Fig. 4

**B. Equipment storage and installation requirements.**

The equipment should be stored or installed in a shady, moderately temperate, ventilated and dry place.

**C. The equipment should be unloaded and transferred by forklift.**



Fig.5

**D. SPECIFICATIONS OF CONCRETE (See Fig. 6)**

Concrete specifications must be followed accordingly.

**WARNING: Failure to do so may result in lift and/or vehicle falling.**

1. Concrete must be 4 inches minimum thickness, without reinforcing steel bars, and must be completely cured before lift installation.
2. Concrete must be in good condition and must be of test strength of 3,000psi (210kg/cm<sup>2</sup>) minimum.
3. Floors must be level with no cracks or holes.

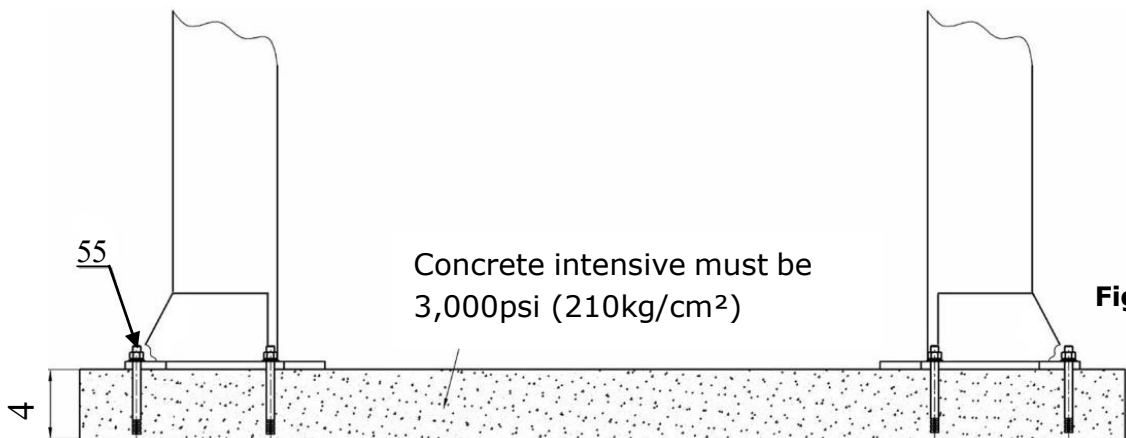


Fig.6

**E. POWER SUPPLY**

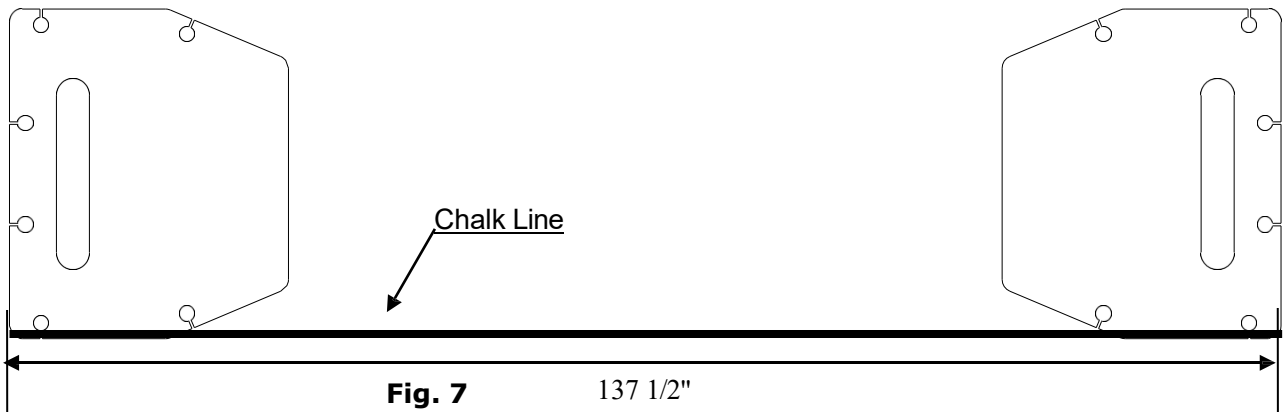
220 volt single phase motor on a 30 amp breaker with minimum of 10 gauge wire. Operating voltage range is 208v-230v.

### III. INSTALLATION STEPS

#### A. Location of installation

Check and ensure the installation location (concrete, layout, space size etc.) is suitable for lift installation.

#### B. Use a carpenter's chalk line to establish installation layout of baseplate. (See Fig. 7)

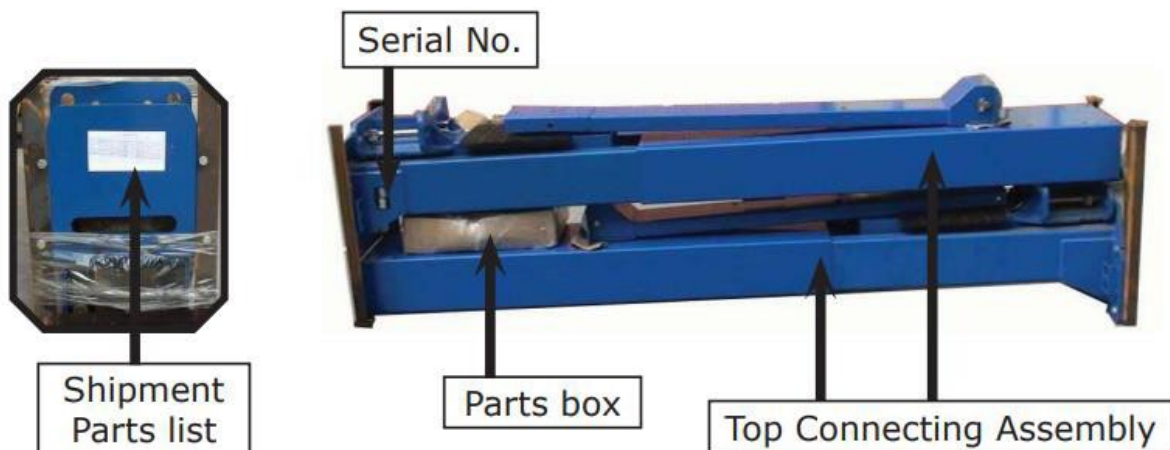


#### C. Check the parts before assembly.

##### 1. Packaged lift and hydraulic power unit (See Fig. 8).



##### 2. Move the lift aside with a forklift or hoist, and open the outer packing carefully and move aside the top connecting assy. and parts box (See Fig. 9).



- Lift the upper column with a forklift or hoist and loosen the bolts on the upper package stand.  
Remove the upper column and take out the parts in the bottom column. (See Fig. 10)

Fig. 10



- Lift the lower column with a forklift or hoist and remove the parts from the inner column (See Fig. 11).

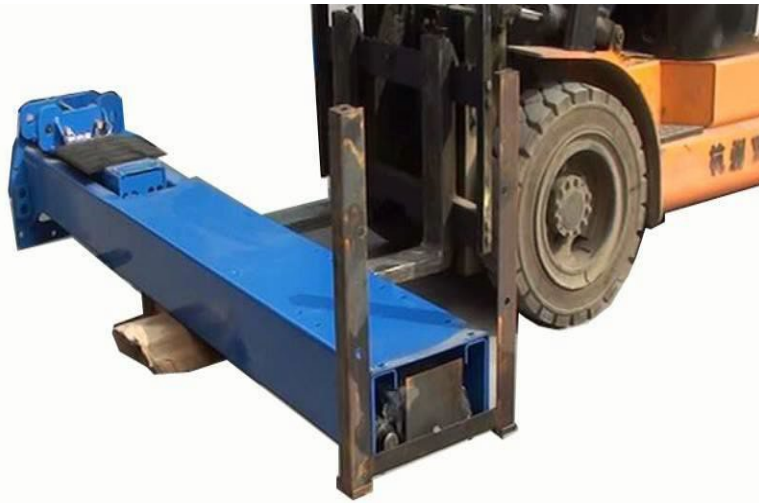
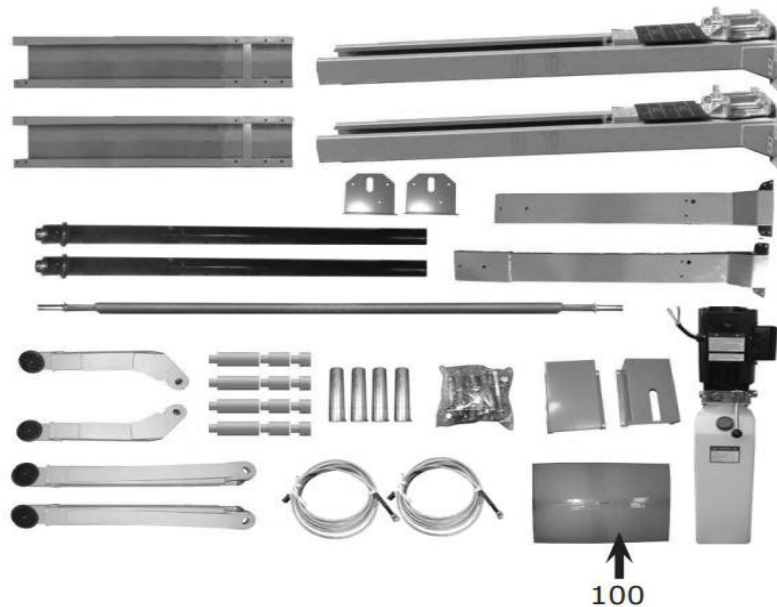


Fig. 11

- Move aside the parts and check the parts according to the shipment parts list. (See Fig. 12 & Fig. 13).

Shipment parts list Fig.12







Pars box (115) Fig.13

6. Check the parts of the parts bag 1 according to parts bag list (See Fig. 14).

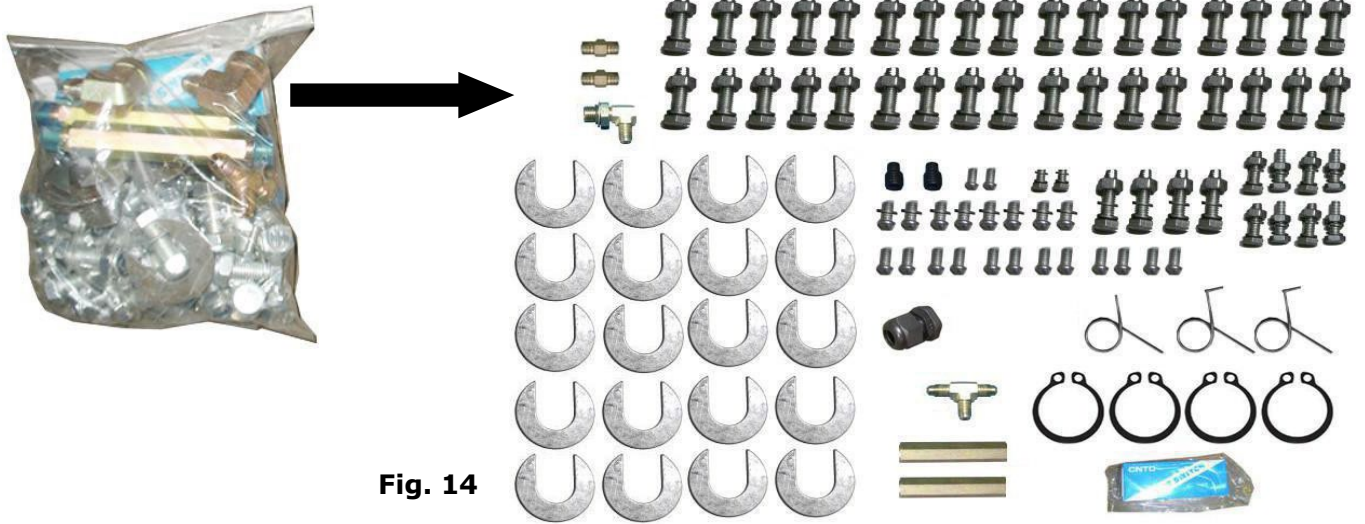


Fig. 14

7. Check the parts of the parts bag 2 according to parts bag list (See Fig. 15).

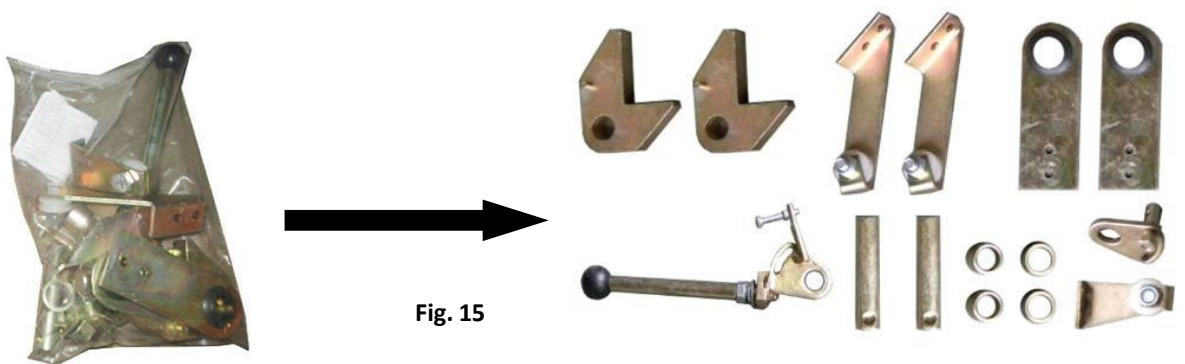
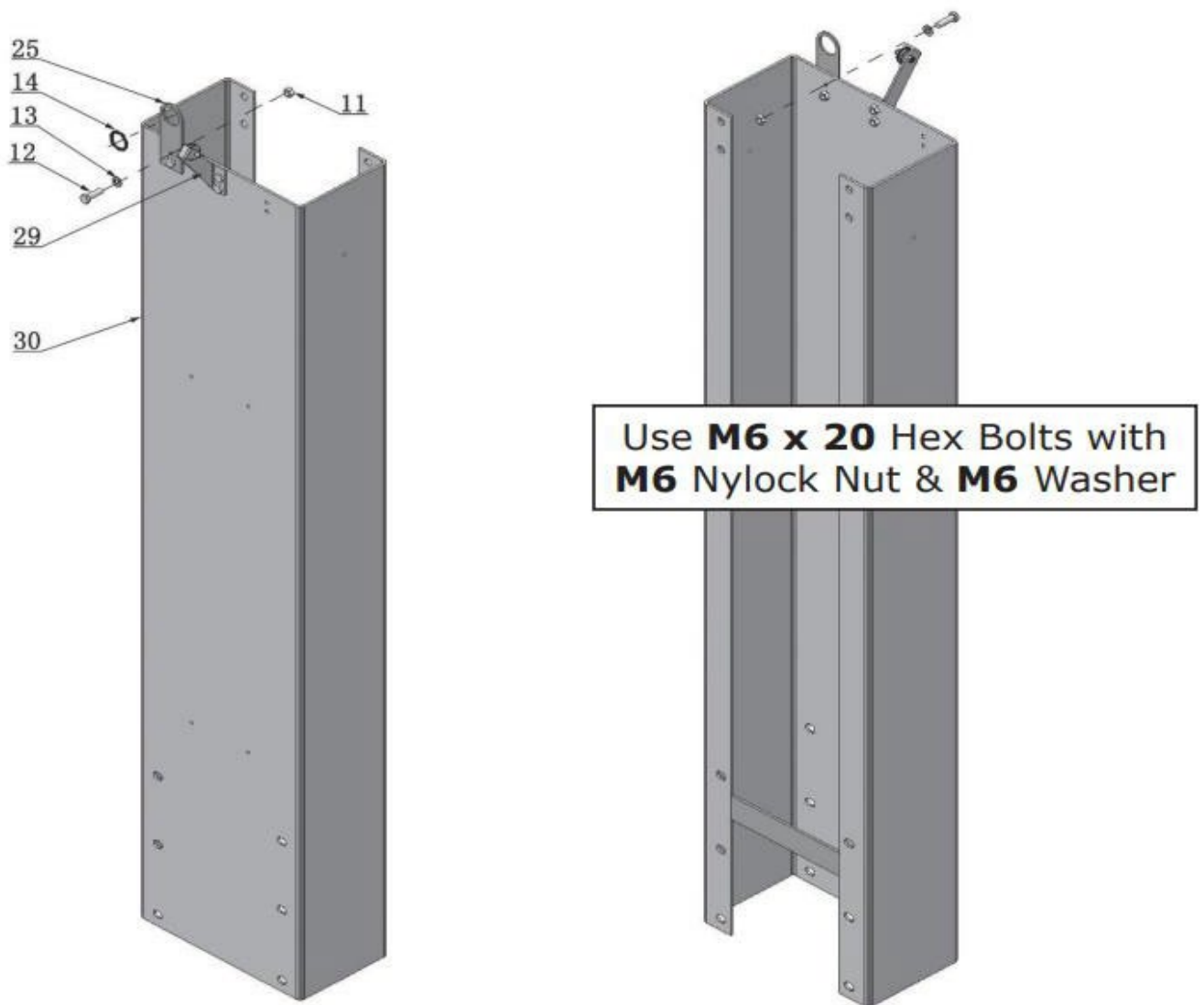


Fig. 15

**D. Install the hydraulic hose and lock release cable brackets on extension columns**

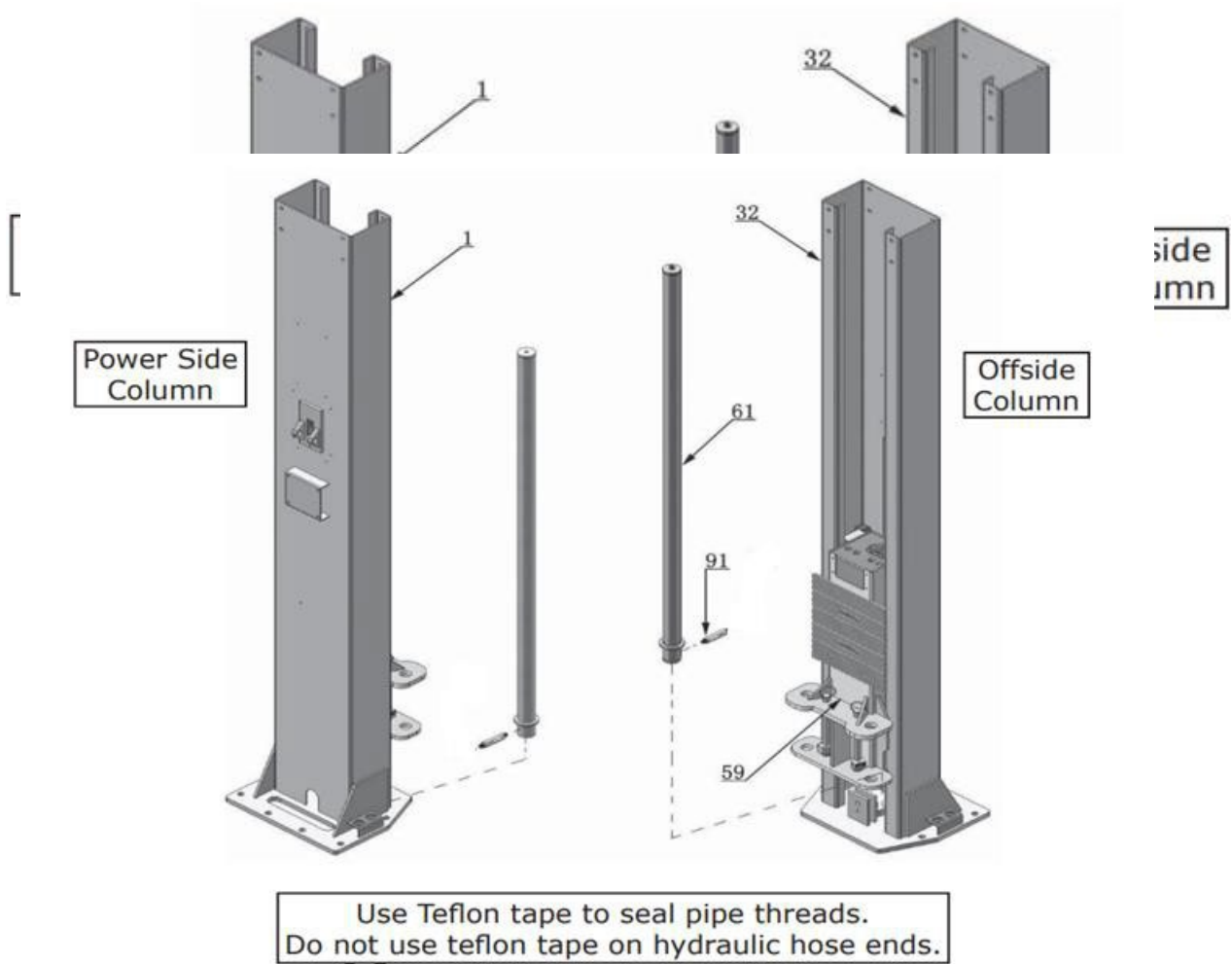
(See Fig. 16).



**Fig.16**

### E. Install hydraulic cylinder

Wrap both ends of straight fittings with white Teflon tape, install straight fitting in each cylinder (See Fig. 17).



The fitting of the cylinder toward the hole of the column

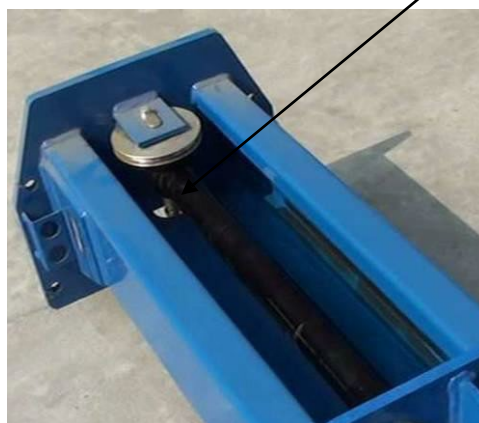


Fig. 17

## F. Install columns

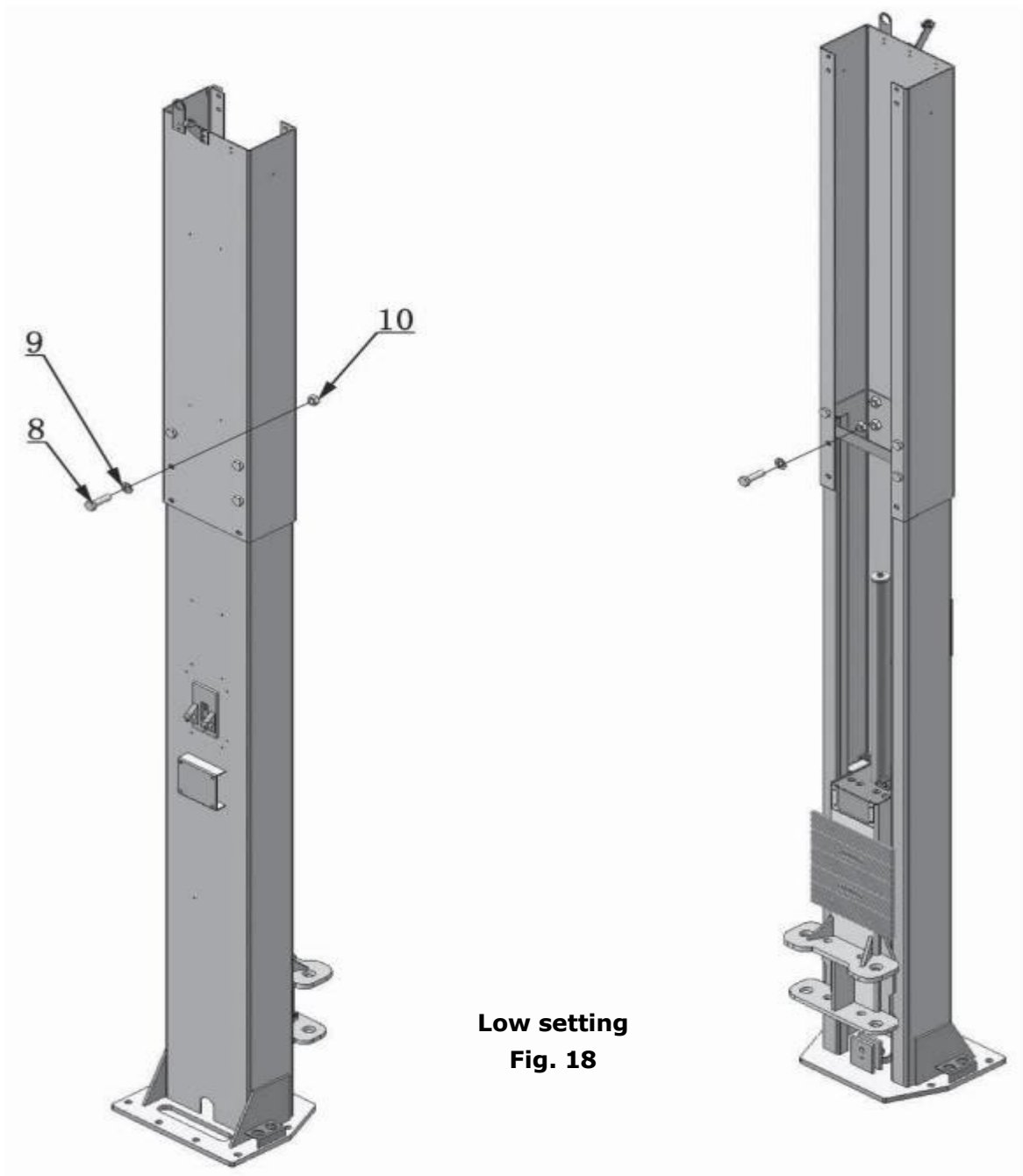
Lay down two columns on the installation site parallel of each other.

Position the

power side column according to the installation site. This lift is designed with

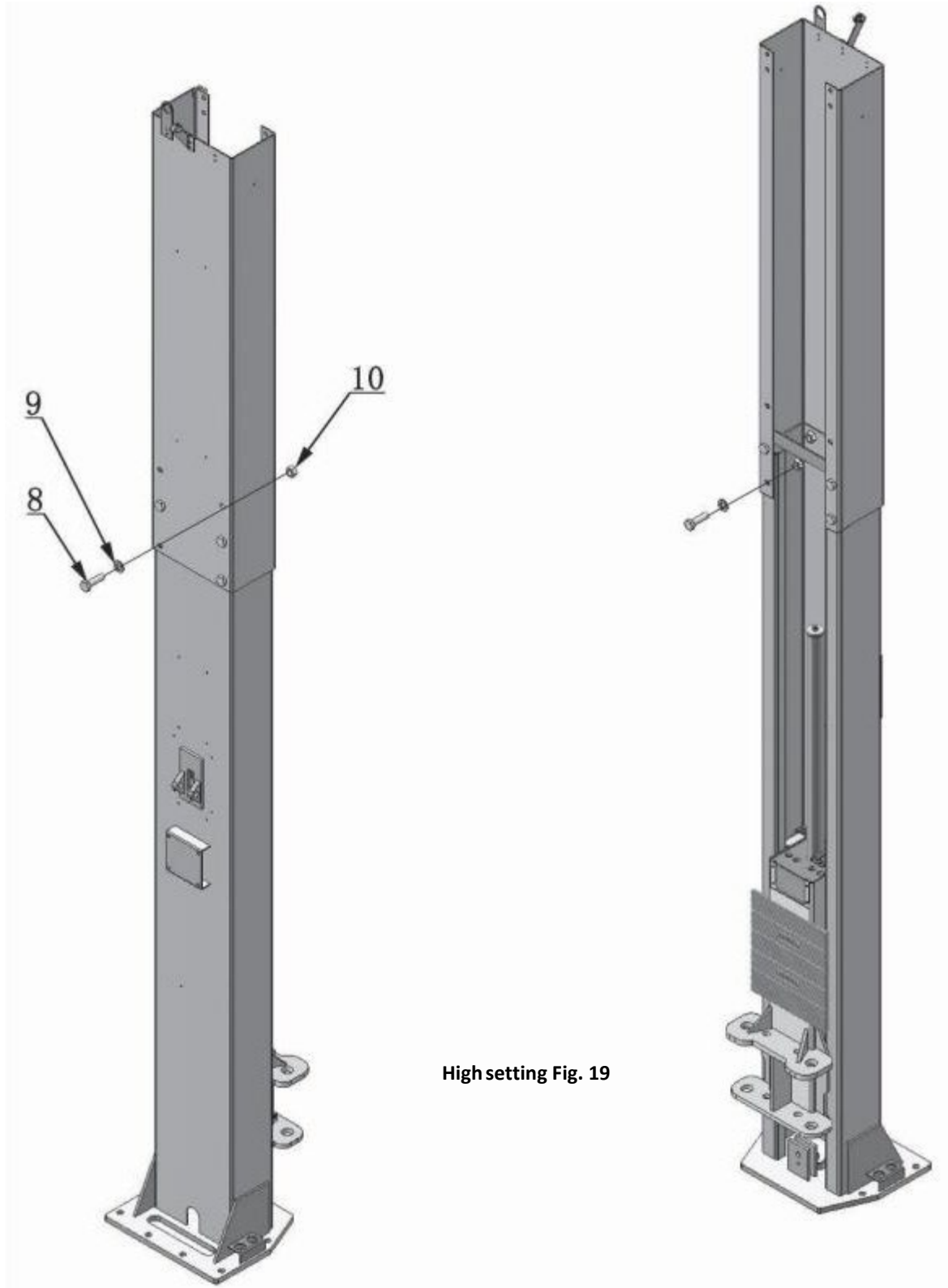
2-section columns. Adjust lift height according to the ceiling height and connect the inner and extension columns.

1. When the ceiling height is less than 147 5/8", connect the extension columns with the top and middle holes on the extension (See Fig. 18)



**Low setting  
Fig. 18**

2. When the ceiling height is over 147 5/8", connect the extension columns with the bottom and middle hole on the extension (See Fig. 19)



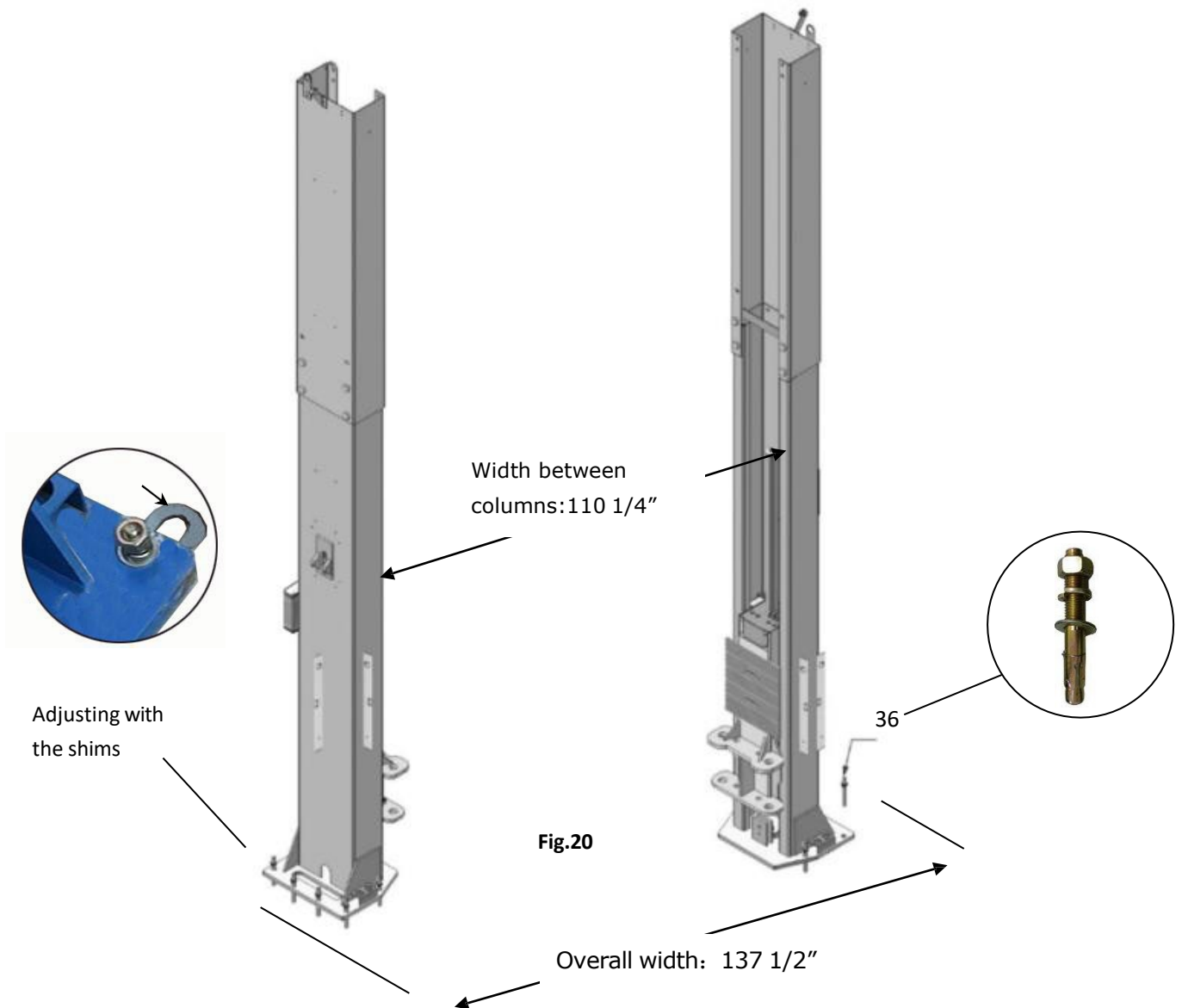
High setting Fig. 19

## G. Position the columns

Position the columns so the base plates line up with a chalk line. Position the offside column parallel to the power side column. Install the overhead cross beam. Level and plumb the columns, shim where necessary.

Drill 3/4" anchor holes. If the top of the anchor exceeds 2 inches above the floor grade, you **DO NOT** have enough embedment, tighten the anchor bolts to 125 Ft Lbs.

**Do not drill holes for anchor bolts until overhead cross beam has been installed.** (See Fig. 20)



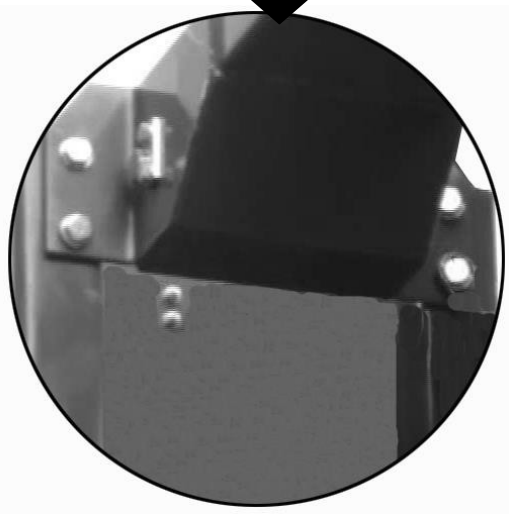
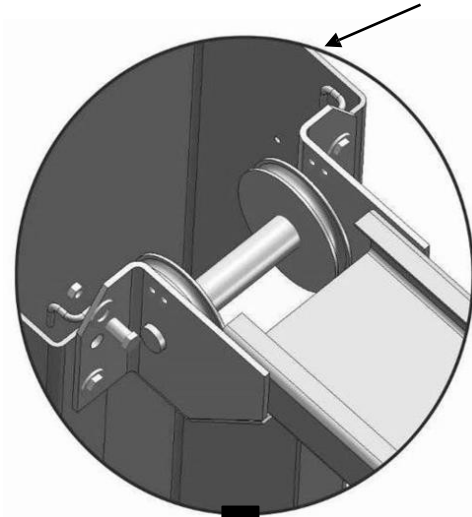
**Note:** Minimum embedment of Anchors is 4\".



## H. Install overhead top beam

1. With help of the hook of top beam, put one side of top beam on top of the extension column and connecting the top beam to extension column by bolts, tighten the bolts. (See Fig. 21).

Hook on the extension columns



Tighten the bolts

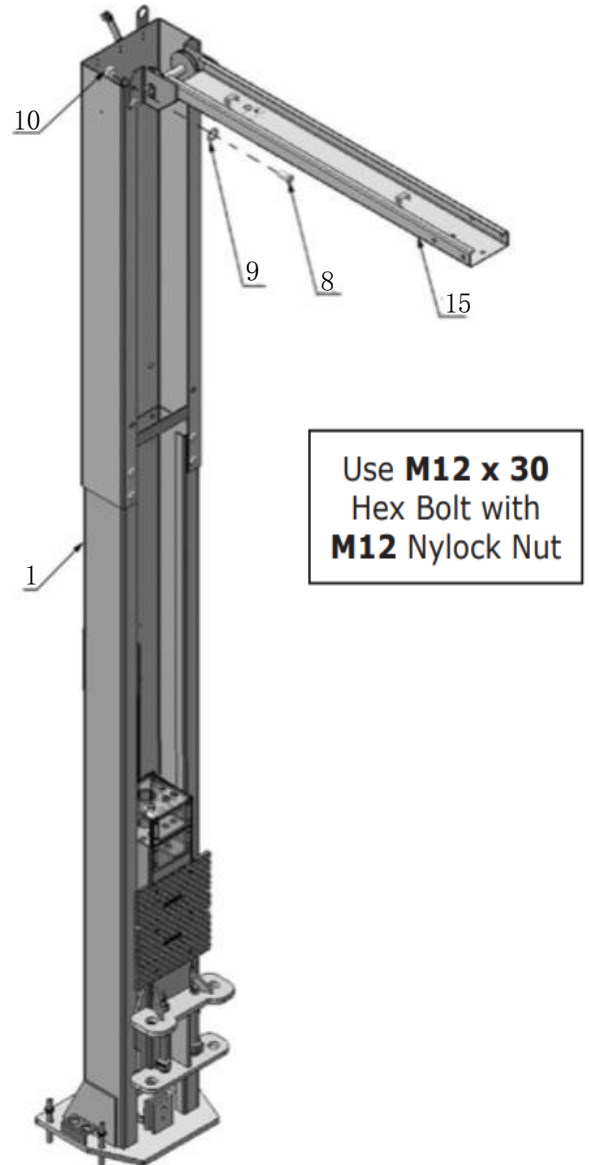
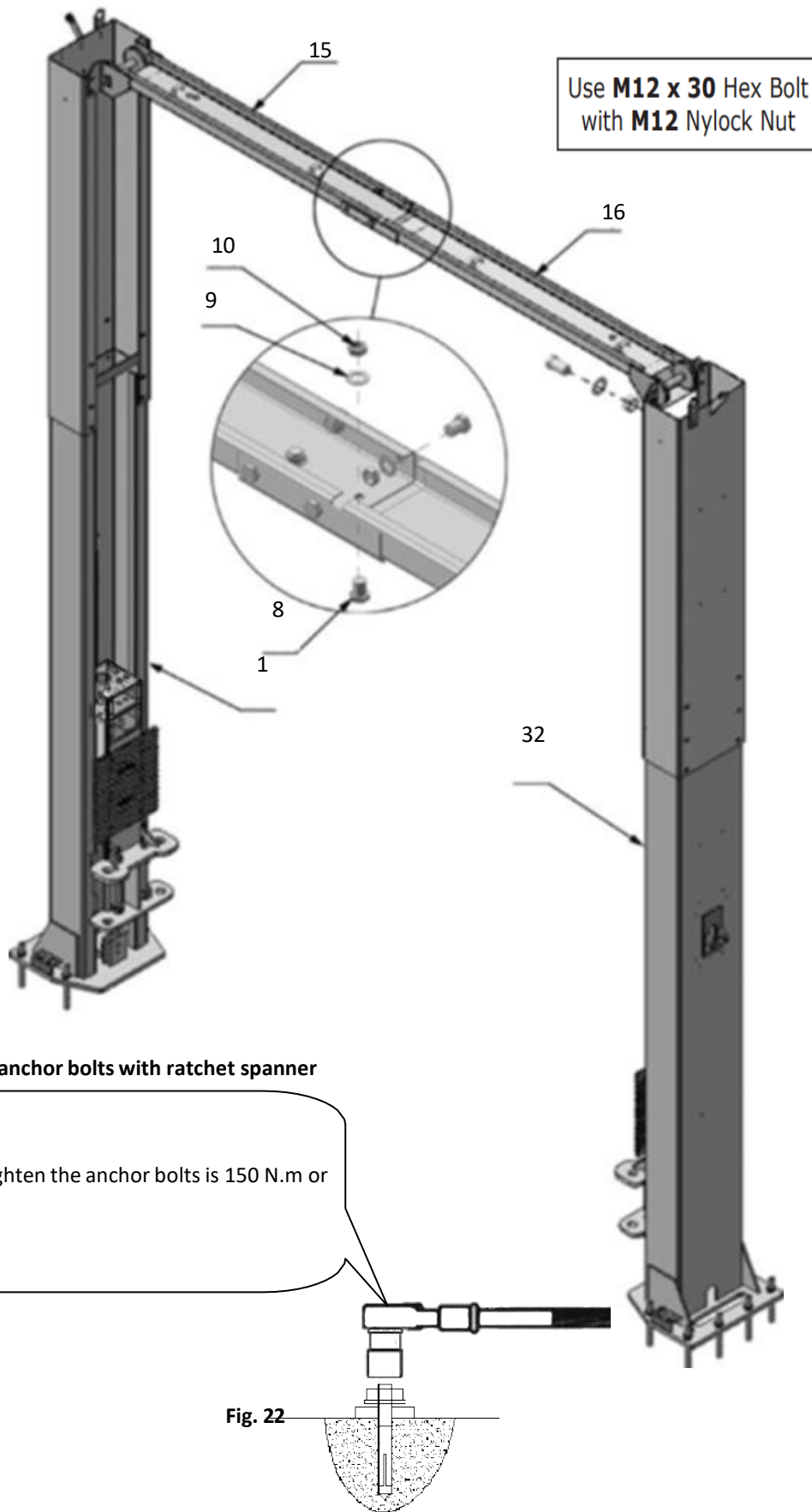


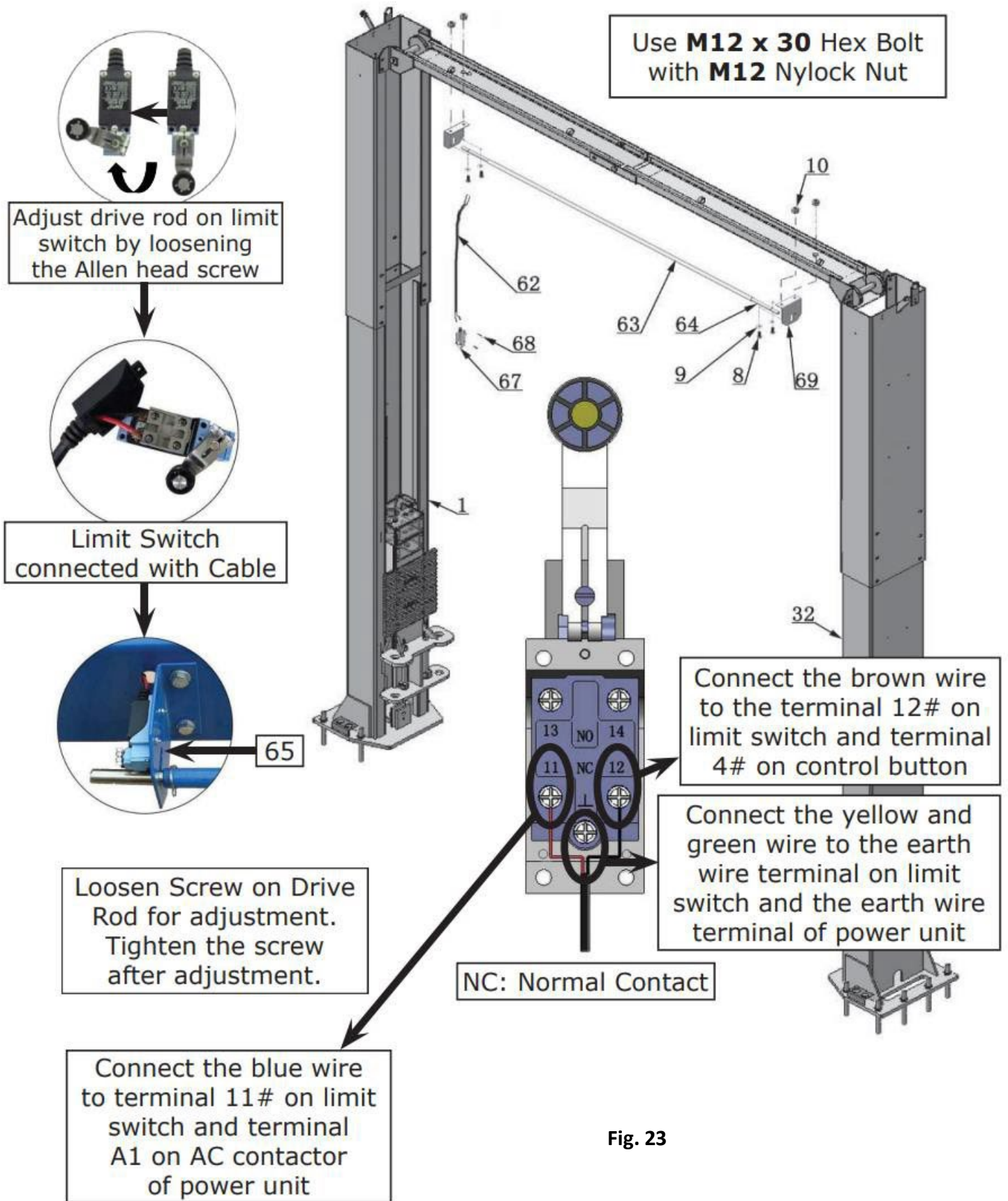
Fig. 21

2. Assemble overhead top beam, tighten the columns anchor bolts (See Fig. 22).

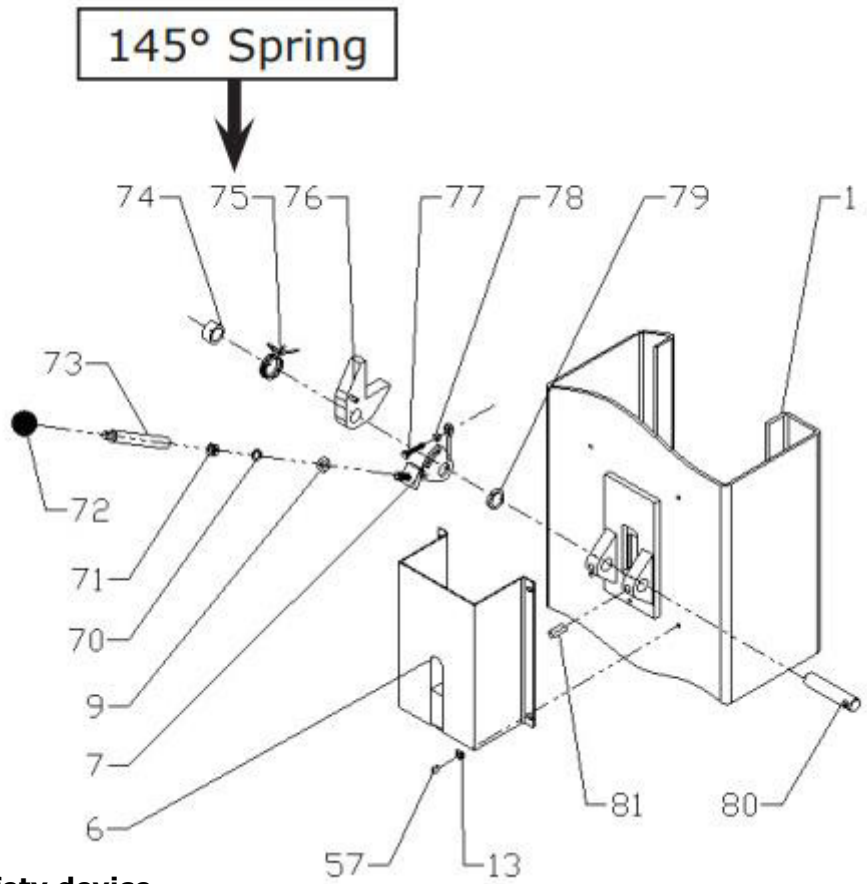




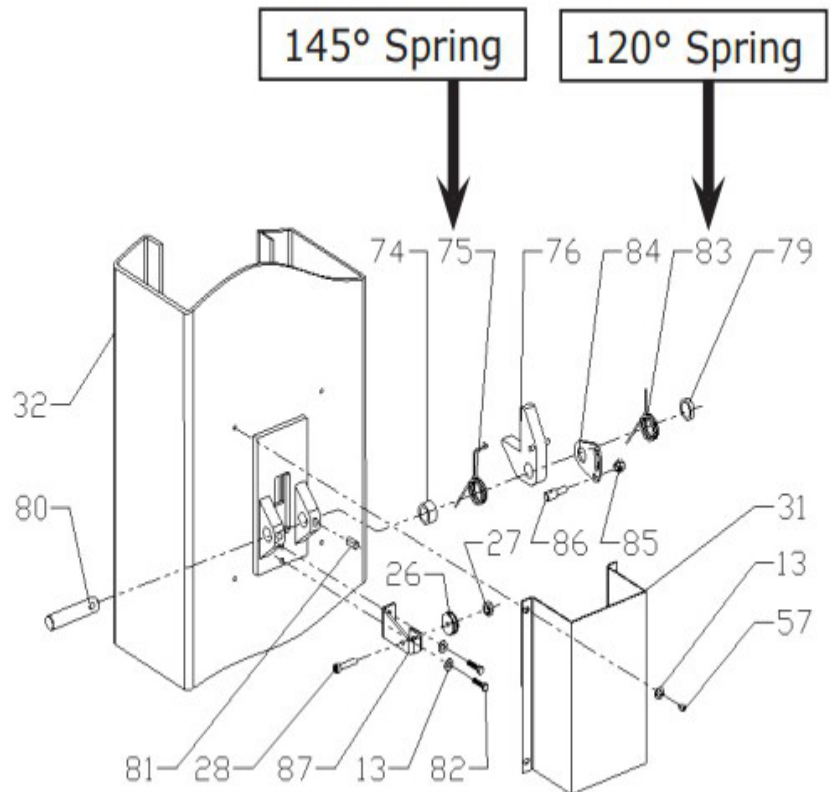
I. Installing the limit switch control bar and limit switch (See Fig. 23)



**J. Install safety device (See Fig. 24 & Fig. 25).**

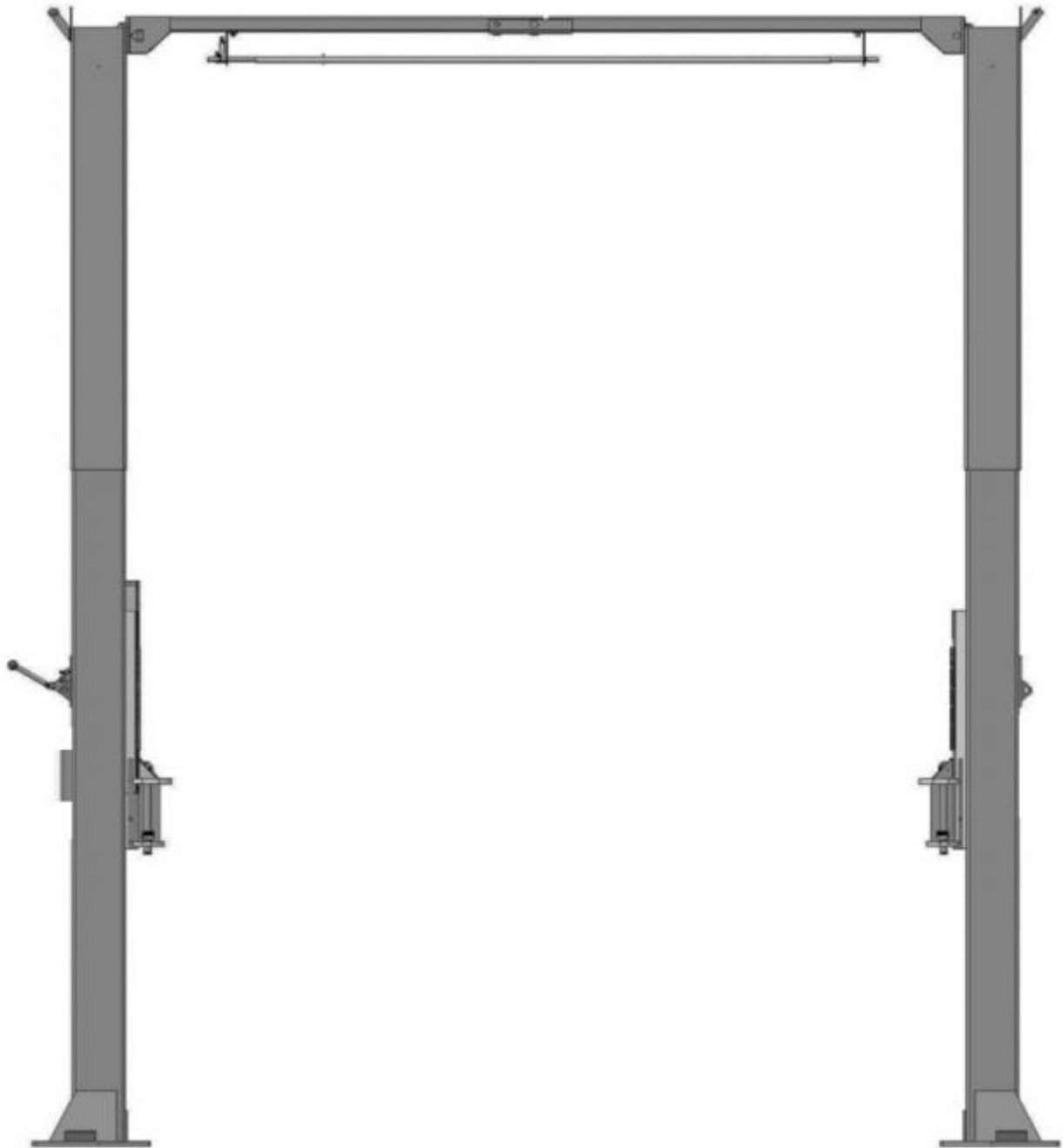


**Fig. 24 Power side safety device**



**Fig. 25 Offside safety device**

**K.** Lift the carriages up manually and set on the 1<sup>st</sup> set of locks. (See Fig. 26).



**Fig. 26**

## L. Install cables

### 1. High setting cable connection:

1.1 Take out the carriage's plastic cover, cable pass through from the bottom of the carriages and be pulled out from the open of carriages, then screw the two cable nuts (See Fig. 27).

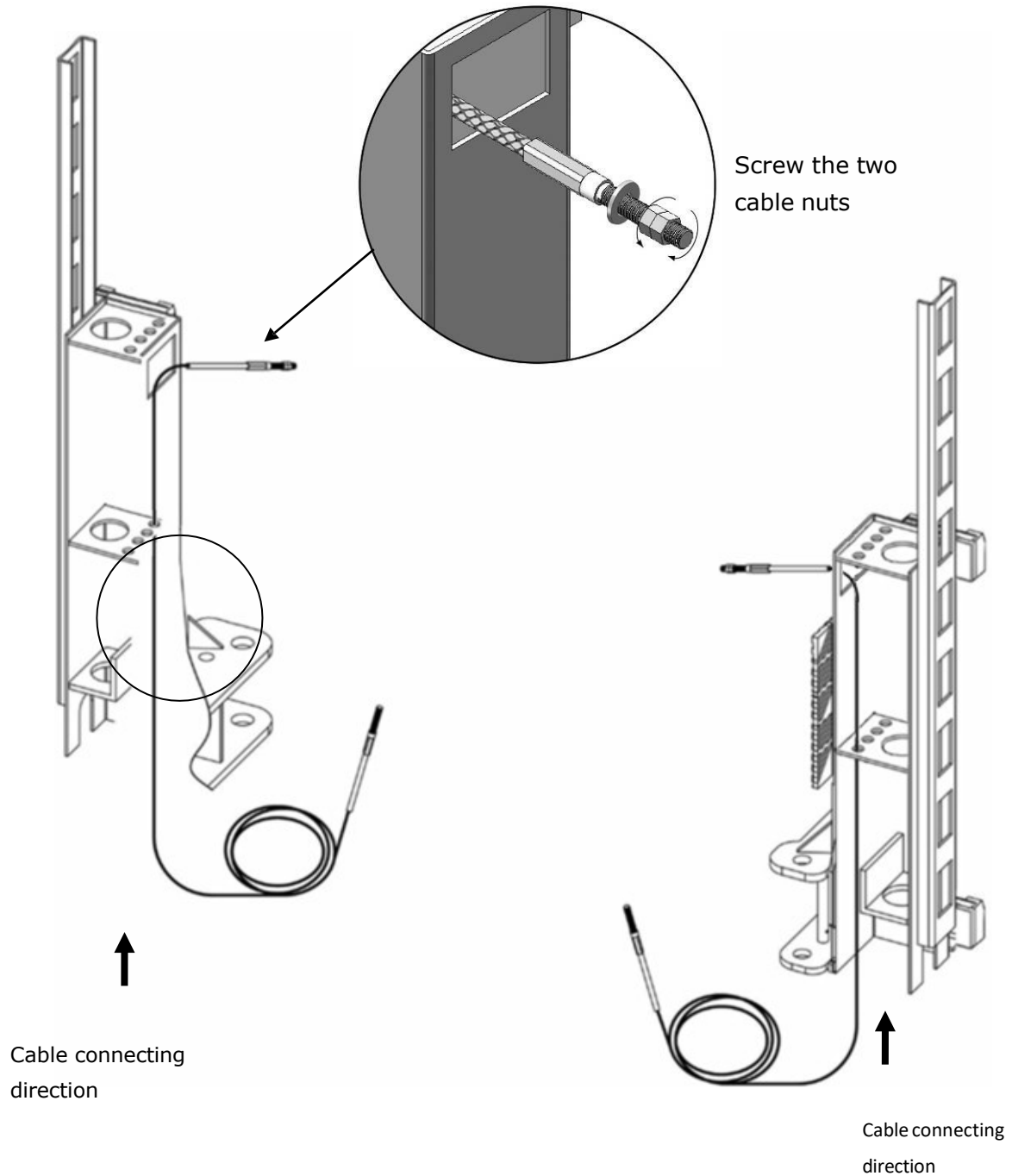


Fig. 27

1.2 Connecting cable for high setting (See Fig. 28)

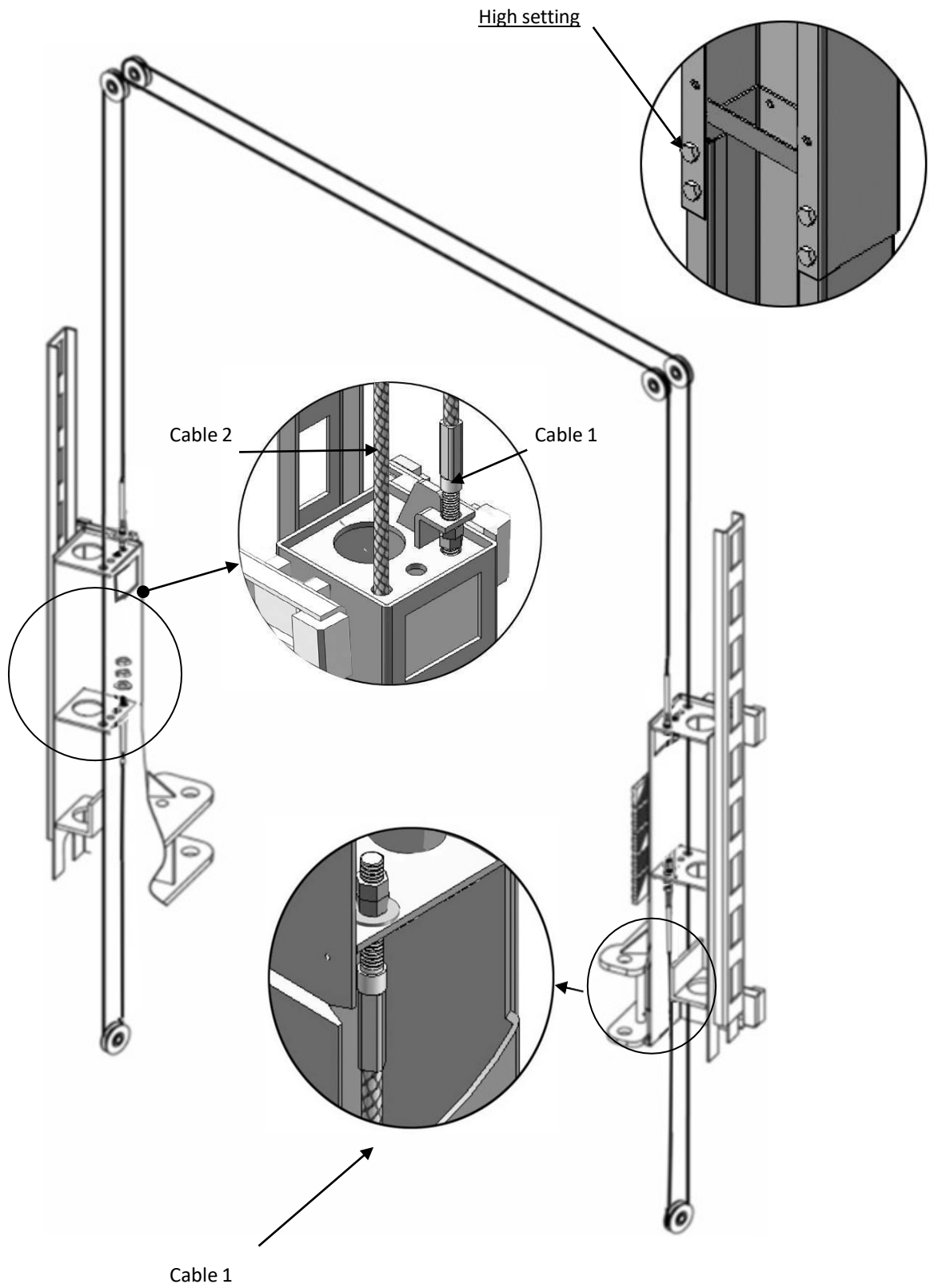
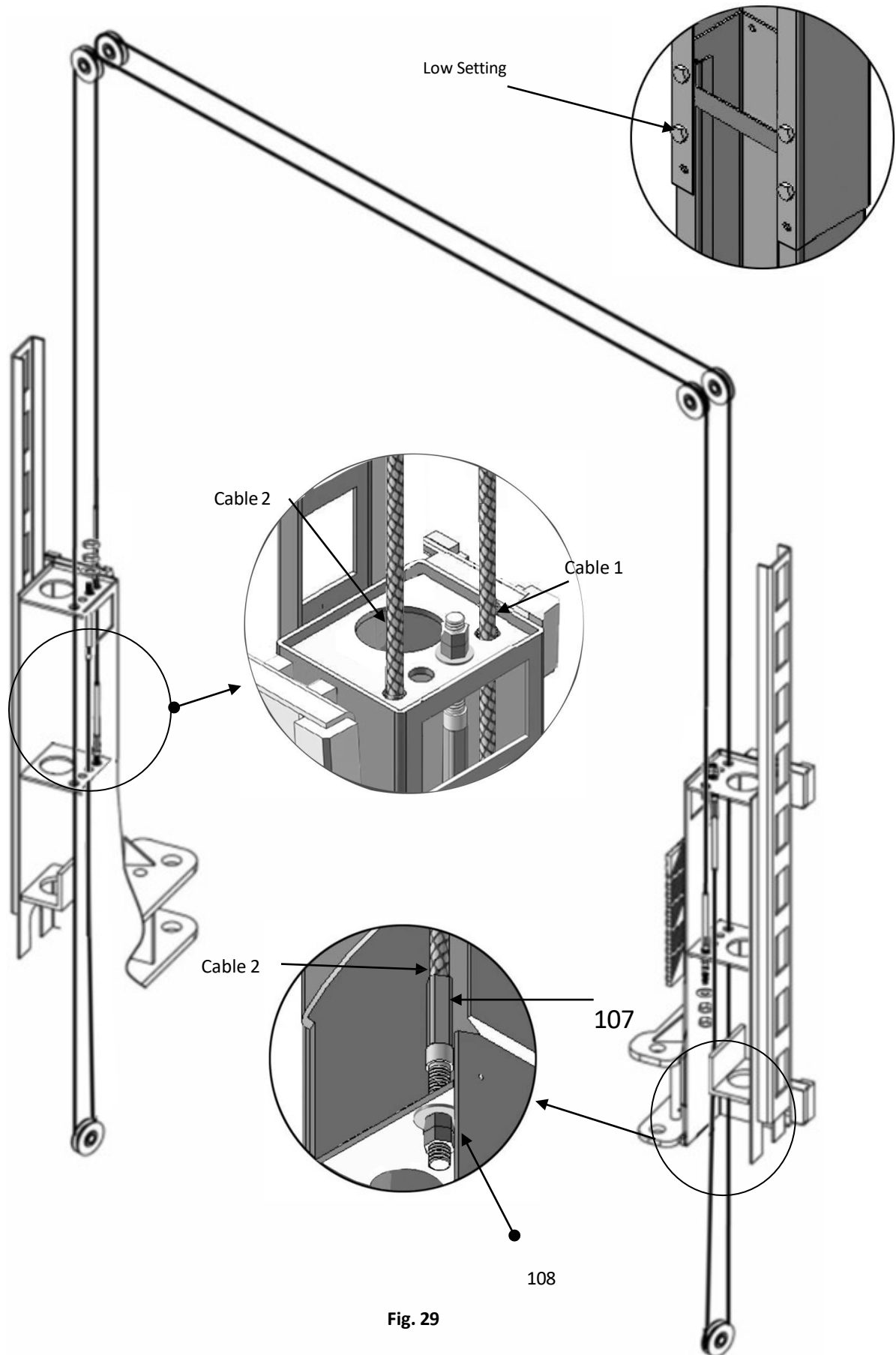


Fig. 28

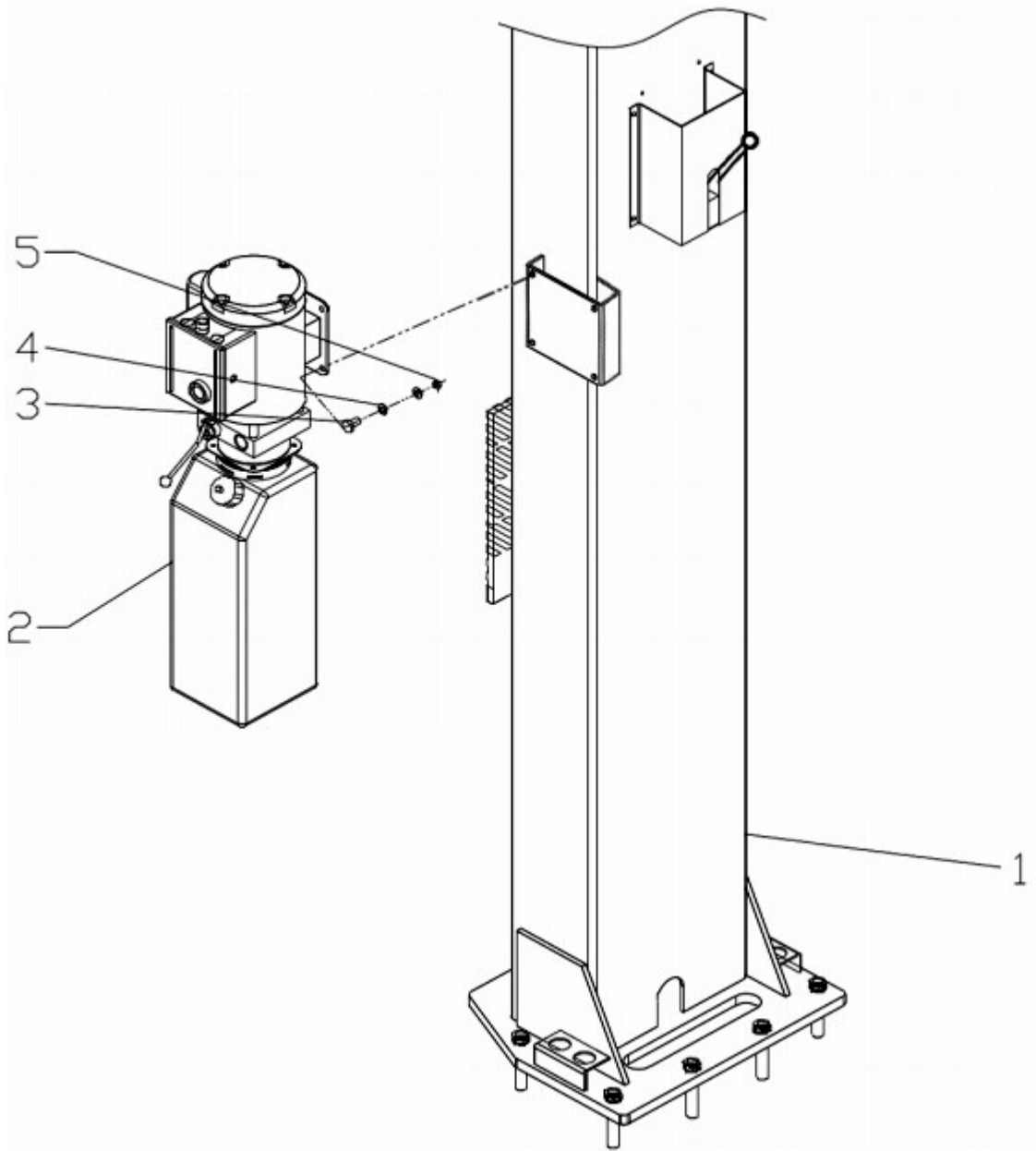
**2. Low setting cable connection (See Fig. 29).**

**Note: Cable should go inside of the carriage.**



**Fig. 29**

**M. Install power unit (See Fig. 30)**



**Fig. 30**

## N. Install oil hose

At high setting and low setting oil hose connection (See Fig. 31).

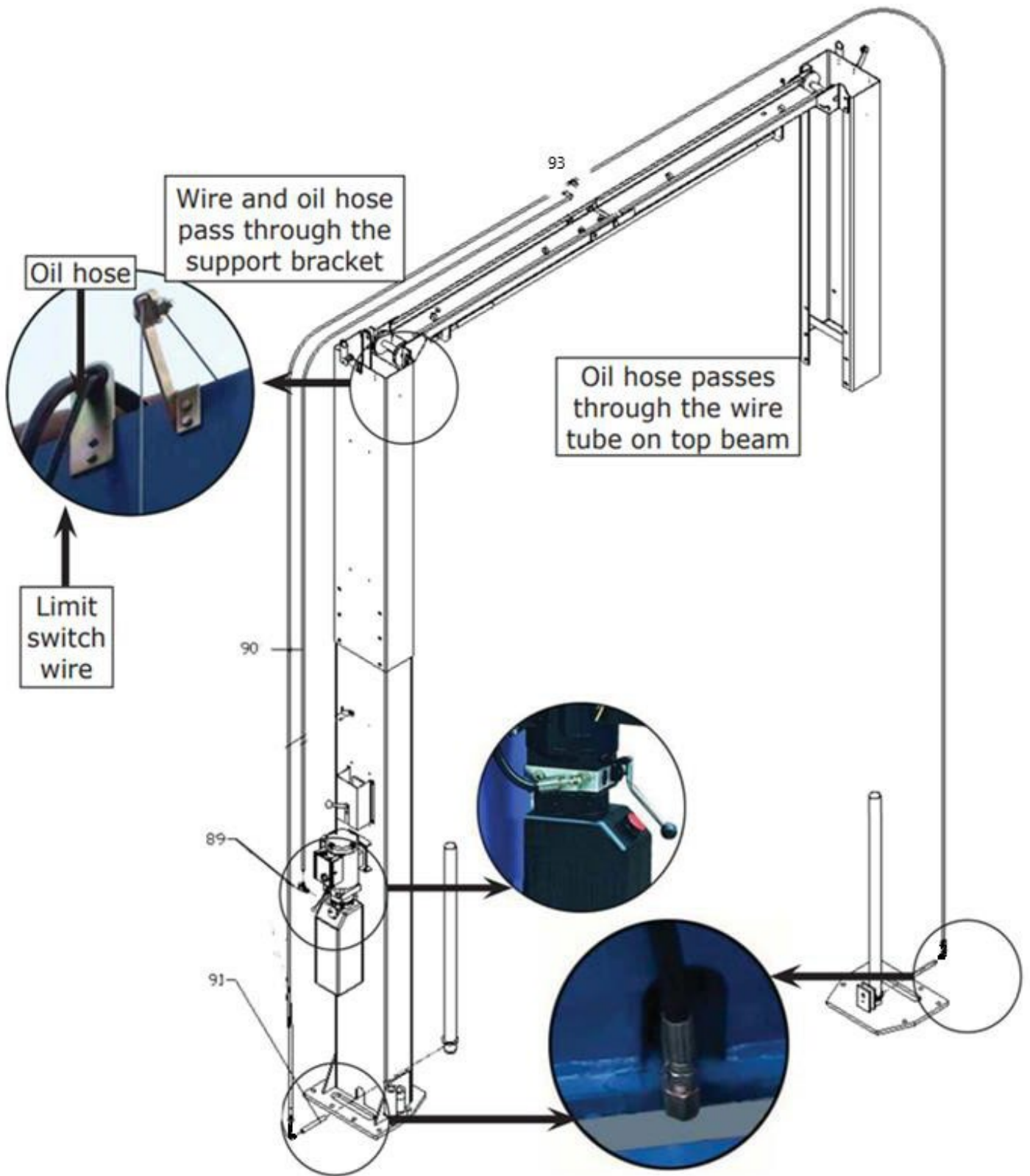
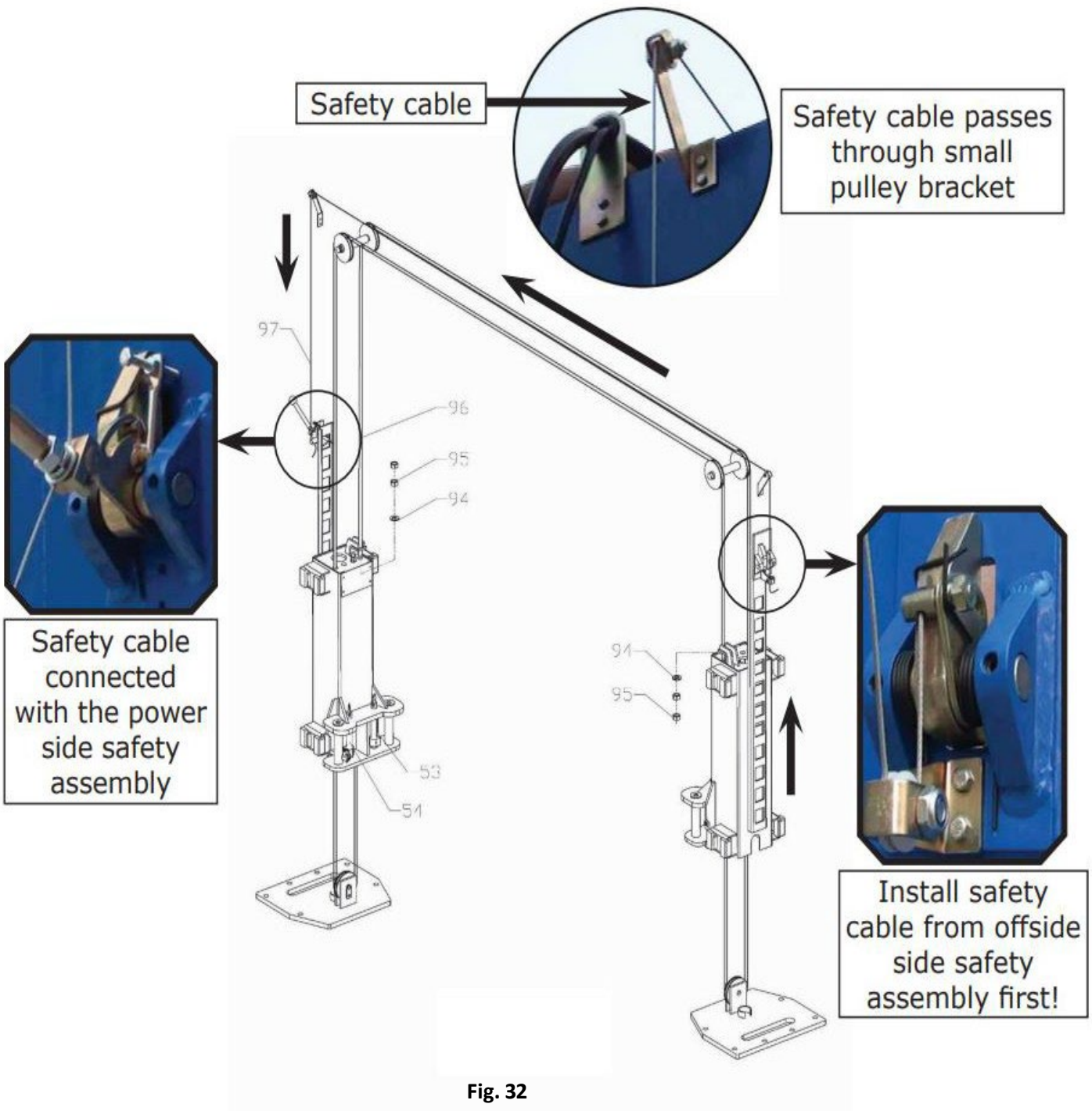


Fig. 31



**O. Install safety cable.**

Install safety cable from offside safety device to power-side safety device, pass through the top beam (See Fig. 32)



P. Install hose retainers on both columns (See Fig. 33).

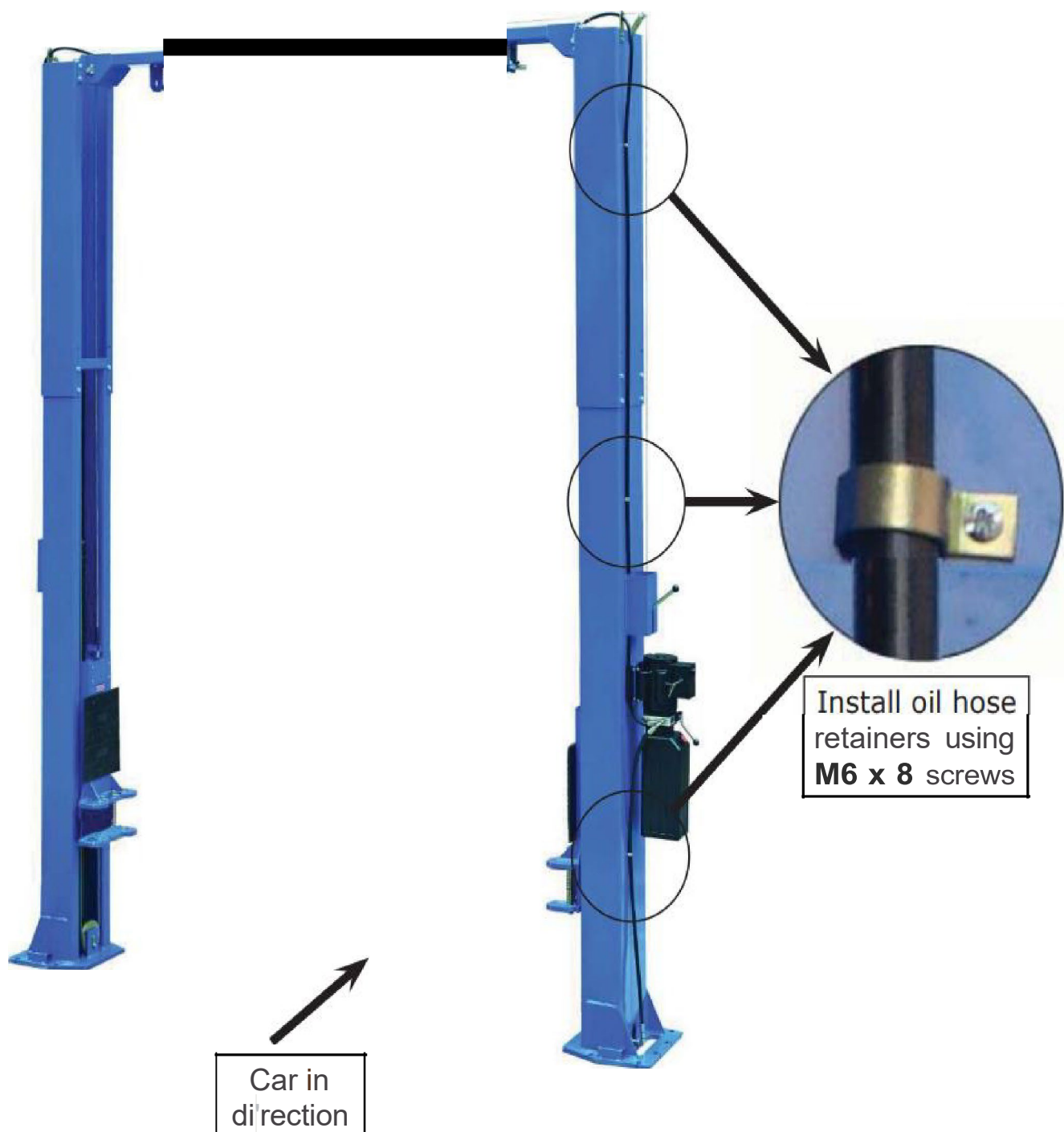
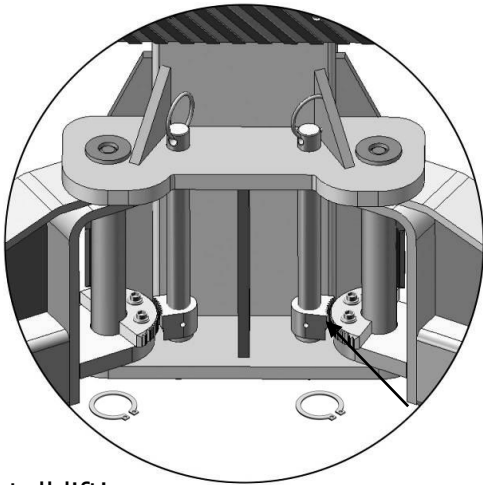


Fig. 33

**Q. Install lifting arms and adjust the arm locks**

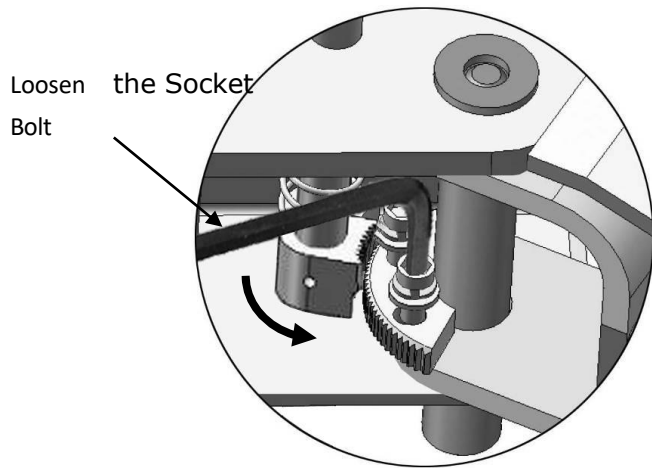
1. Install lifting arms (See Fig. 34).
2. Lower the carriages down to the lowest position, then use an 8mm allen wrench to loosen the socket bolt (See Fig.35).
3. Adjust moon gear as direction of arrow (See Fig.36).
4. Adjust moon gear and arm lock to make it to be meshed, then tighten the socket bolts of arm lock (See Fig.37).



Install lifting arms

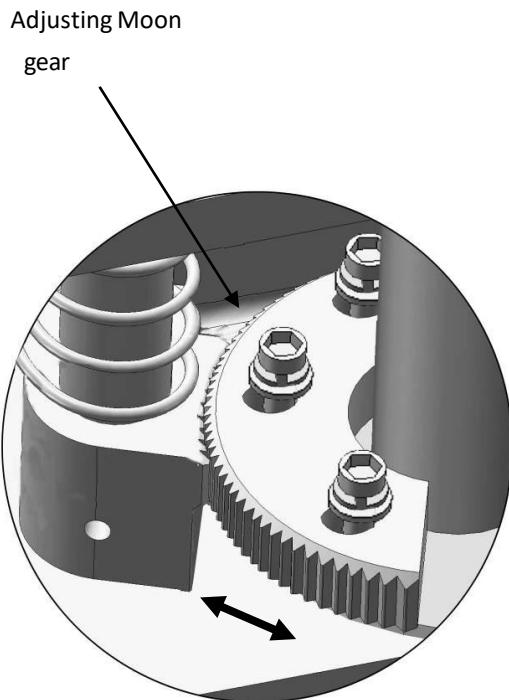
Snap Ring

**Fig. 34**

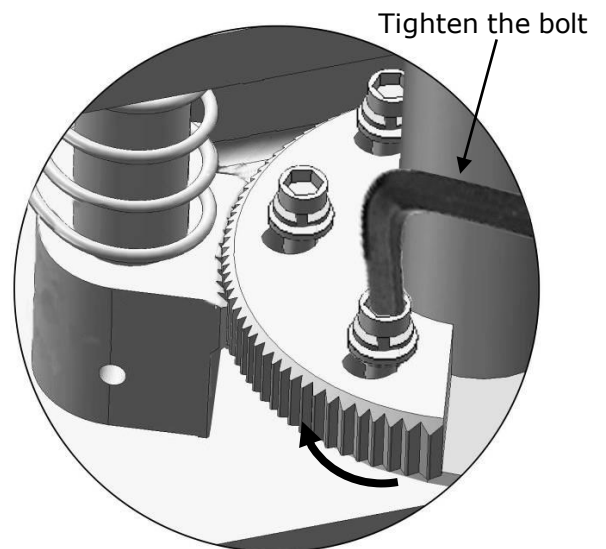


**Fig. 35**

use the 8# socket head wrench to loosen the socket bolt



**Fig. 36**



**Fig. 37**

Locking the bolts after the moon gear and arm lock engaged well

**R. Tighten All Hydraulic Fittings and Fill the reservoir with Hydraulic Oil. Approximately 4 gallons are required.**

**Note: For the best performance it is recommended to use AW32 or AW46 series hydraulic oil.**

**S. Install electrical system**

Connect the power source according to the data plate on the Power Unit.

**Remove the short “Pig Tail” wire connected to the AC contactor terminals.**

**This wire was used to test the motor after production.**

**CAE Single phase motor**

**Please Note: This motor is powered by Alternating Current and the terminals on the AC contactor are not wire color specific. There are no positive or negative terminals.**

**Single phase motor (See Fig. 38).**

**Read this manual thoroughly** before installing, operating, or maintaining this lift. When done with installation be sure to return documents to package and give all materials to lift owner/operator. When installation is complete be sure to run lift up and down a few cycles with and without “typical” vehicle loaded on lift.



# IV. EXPLODED VIEW

## Model PV10

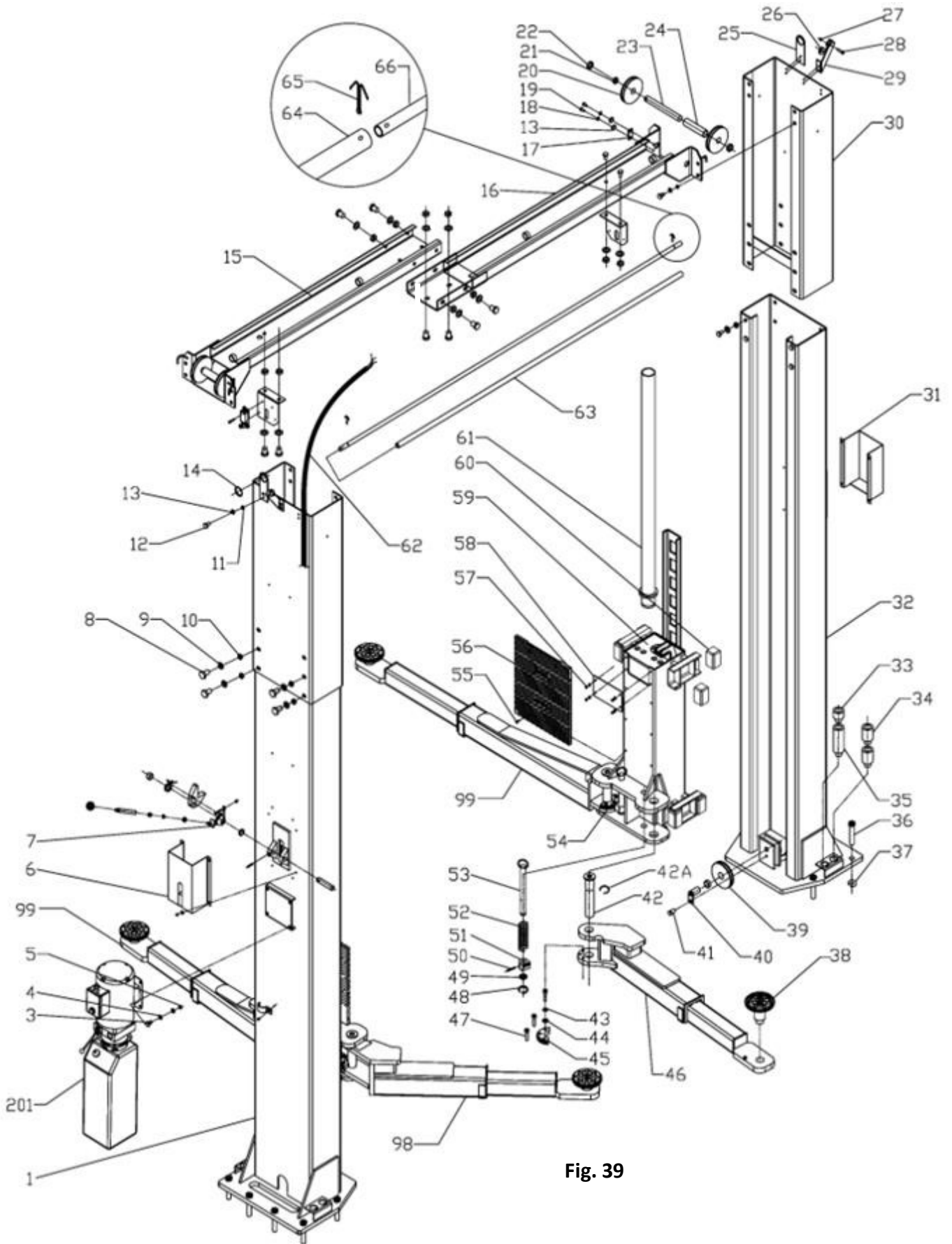


Fig. 39

**PV-10P PARTS LIST**

Item	Part #	Description	Qty
1	217001B	Power side Column	1
2/201	POWERUNIT220VETL	Power unit	1
3	209003	Bolt	4
4	209033	Lock Washer	4
5	209005	Nut	4
6	QL4L-520-00	Power side Lock Cover	1
7	QL4L-210-00	Main Cam Lock	1
8	217069	Bolt	34
9	206006	Washer	35
10	206023	Self-Locking Nut	34
11	420018	Self-Locking Nut	8
12	217013	Bolt	8
13	420045	Washer	26
14	217025	Protective Ring	2
15	217169	Right Overhead Bar	1
16	217170	Left Overhead Bar	1
17	420044	Pin Stop	2
18	209149	Washer	8
19	420138	Bolt	4
20	QL4L-400-02	Top Pulley	4
21	217020	Bronze Bush for Pulley	6
22	217021	Top Pulley Spacer	4
23	217022	Pin	2
24	217033	Pin Spacer	2
25	217024	Hose Support	2
26	QL4L-000-10	Plastic Small Pulley	3
27	209056	Self-Locking Nut	3
28	209046	Bolt	3
29	217026	Safety Cable Bracket	2
30	217027	Extension Column	2
31	QL4L-410-00	Offside Lock Cover	1
32	217034B	Offside Column	1
33	QL40-000-04	Adapter 1.25"	4
34	209052B	Adapter 2.5"	4
35	QL40-000-05	Adapter 5"	4
36	WA34512	Anchor Bolt	12
37	620065	Shim	10
38	217114A	Rubber Pad Assembly	4
39	217036	Bottom Pulley	2
40	217037	Bottom Pin	2
41	209038	Bolt	6

Item	Part #	Description	Qty
42	217168	Arm Pin	4
43	209039	Lock Washer	18
44	209022	Washer	18
45	206049	Moon Gear	4
46	217041A	Left Front Arm	1
47	206048	Allen Bolt	12
48	206032	C-Clip	4
49	217043	Limit Ring	4
50	206036	Roll Pin	4
51	217044	Arm Lock	4
52	217045	Spring	4
53	217046A	Left Arm Lock Bar	2
54	217046	Right Arm Lock Bar	2
55	209019	Flat Head Screw	12
56	217053	Protective Rubber	2
57	209009	Cup Head Bolt	26
58	217054	Carriage Plastic Cover	2
59	217197-N	Carriage	2
60	217188	Slider Block	16
61	PV10-9100	Cylinder	2
62	217171	Wire Cable	1
63	206025A	Foam Cushion	1
64	206129	Limit Bar	1
65	201005	Split Pin	2
66	206025C	Limit Bar Link	2
67	LX19-001	Limit Switch	1
68	206011	Cup head Bolt	2
69	206042	Limit Bar Bracket	2
70	420026	Lock Washer	1
71	206023A	Nut	1
72	217005	Plastic Ball	1
73	217006	Lock Handle	1
74	217007	Large Spacer	2
75	QL4L-200-02	Main Spring	2
76	QL4L-230-00	Main Lock	2
77	217010	Bolt	1
78	217011	Nut	1
79	217012	Small Spacer	2
80	217050	Main Lock Pin	2
81	217051	Screw	2
82	217066	Bolt	2



Item	Part #	Description	Qty
83	QL4L-200-04	Torsion Spring	1
84	217031	Cam Lock	1
85	217033	Self-Locking Nut	1
86	217032	Cable Lock Hold	1
87	217029	Small Pulley Bracket	1
88	PV10-4003	Oil Hose	2
89	305720	90 Fitting for Power Unit	1
90	PV10-4004	Oil Hose	1
91	PV10-4021	Extended fitting for Cylinder	2
93	SW-001	Hydraulic T-Fitting	1
94	420029	Cable Nut Washer	4
95	209066	Cable Nut	8
96	PV10-4500	Equalizing Cable	2
97	217064	Lock Release Cable	1
98	217042A	Right Front Arm	1
99	217049A	Rear Arm	2
100	PV10-N-PBX	Parts Box	1

## V. TEST RUN

### 1. Adjust the equalizing cable (See Fig. 44)

Use wrench to hold the cable end, meanwhile use ratchet to tighten the cable nuts until both cables have the same tension. **If the two carriages do not lift at the same time, screw and tighten the cable nuts on the lower of the two carriages.**

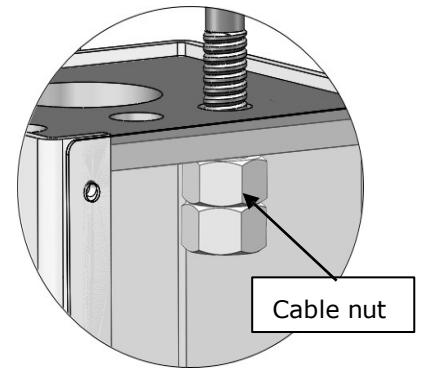


Fig. 44

### 2. Adjust safety cable

Lift the carriages and lock at the same height, pull the safety cable and then release a little, and then tighten the safety cable nuts. Make sure the safety locks click at the same time.

### 3. Bleeding air from oil cylinder (See Fig. 45)

This hydraulic system is designed to bleed air by loosening the bleeding screw on top of the cylinders. Lift the carriages to about 12 inches and loosen the bleeding plug.

Lower the lift until fluid comes out. Tighten the screws after bleeding.

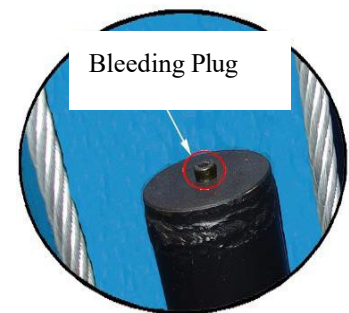
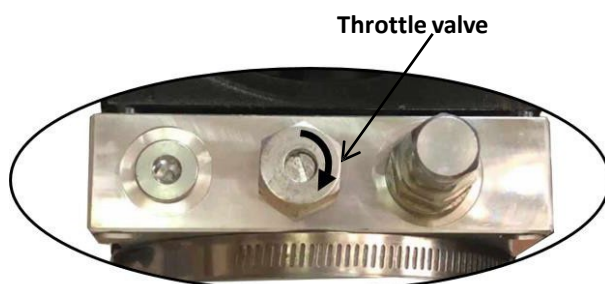


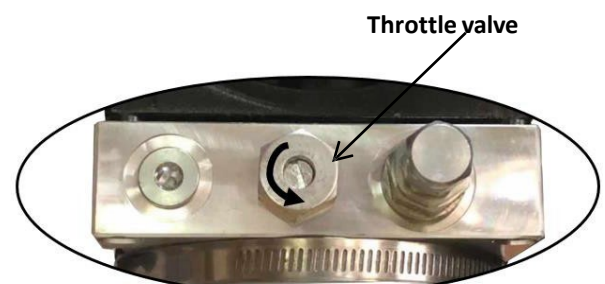
Fig. 45

### 4. Adjust the lowering speed (Only for CAE power unit) (Adjust with a load on the lift) (See Fig. 46)

You can adjust the lowering speed of the lift if needed: Loosen the locking nut on the throttle valve, and then turn the throttle valve clockwise to decrease the lowering speed, or counterclockwise to increase the lowering speed.



Adjust clockwise, decrease lowering speed



Counterclockwise, increase lowering speed

Fig. 46

## 5. Test with load

After finishing the above adjustment, test running the lift with load. Run the lift in low position several times first. Run the lift to the top completely.

**NOTE:** If the lift vibrates on the way up with a load, lubricate all pulley shafts and wear blocks. If the lift vibrates on the way down, the cylinders need to be bled.

Hydraulic Schematic Diagram

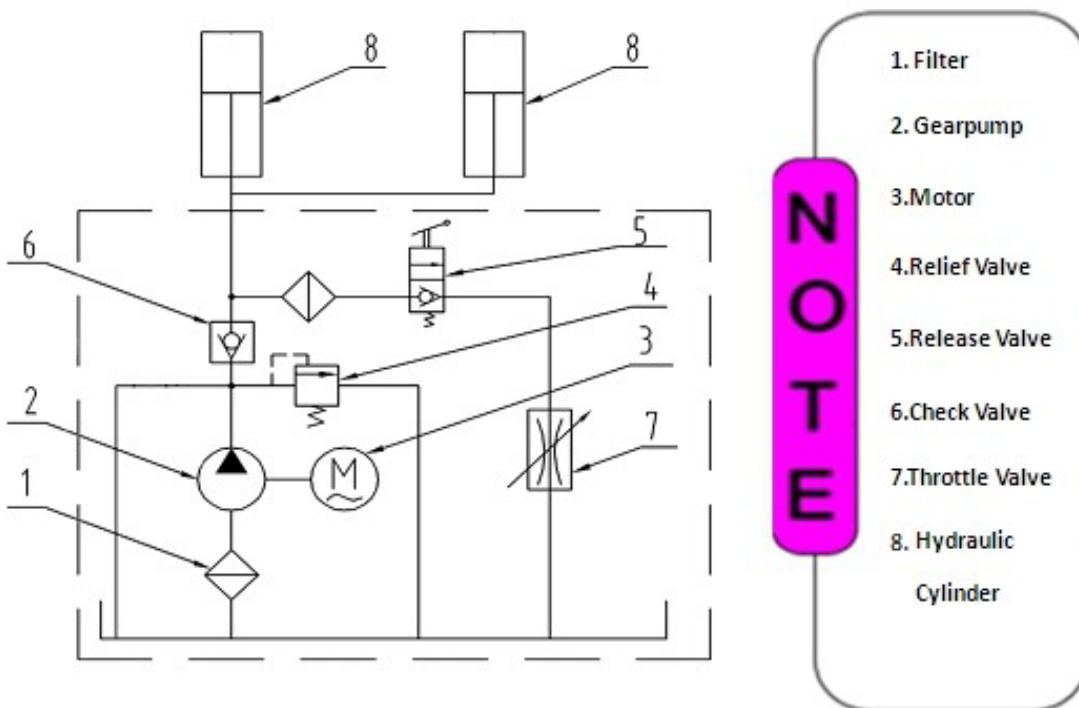


Fig. 47

## **VI. OPERATION INSTRUCTIONS**

### **Please read the safety tips carefully before operating the lift To lift vehicle**

1. Keep the lift area clean and free of clutter;
2. Position lift arms to the lowest position, on floor;
3. Open or swing lift arms away from center of lift;
4. Position vehicle between columns;
5. Move or swing arms to the vehicle's lifting points;

**NOTE: The four lift arms must make contact at the same time with the vehicle's lifting and both axles must rise off the ground at the same time**

6. Push "**UP**" button until the lift pads contact underside of vehicle. Raise vehicle just enough that the wheels are off the floor. Recheck to make sure vehicle is secure.
7. Continue to raise the lift slowly to the desired working height.
8. Push lowering handle to lower lift onto the nearest safety lock. The vehicle is ready to repair.

**NOTE: The lift must always be on the safety locks when holding a vehicle.**

### **To lower vehicle**

1. Keep the lift area clean and free of clutter.
2. Push "**UP**" button to raise the vehicle slightly, and then pull the safety lock handle to release the safety locks, lower vehicle by depressing the power unit lowering handle.
3. Lower the vehicle completely to the floor, until arms no longer contact the vehicle.
4. Open the arms and position them to the shortest length.
5. Drive the vehicle out of the lift.

## **VII. MAINTENANCE SCHEDULE**

### **Monthly:**

1. Re-torque the anchor bolts to 85 Ft Lbs;

**Note: All anchor bolts should take full torque. If any of the bolts do not for any reason, DO NOT use the lift until the bolt has been replaced.**

2. Check all connectors, bolts and pins to ensure proper mounting;
3. Lubricate cable with lubricant;
4. Make a visual inspection of all hydraulic hoses/lines for possible wear or leakage;
5. Check Safety locks and make sure they are in proper condition;
6. Lubricate all Rollers and Pins with 90wt. Gear oil or equivalent;

### **Every six months:**

1. Make a visual inspection of all moving parts for possible wear, interference or damage.
2. Check and adjust as necessary the tension of the equalizer cables to ensure level lifting.
3. Check columns for plumbness.
4. Check Rubber Pads and replace as necessary.
5. Check Safety locks and make sure proper condition.

### **Oil cylinder maintenance:**

In order to extend the service life of the oil cylinder, please operate according to the following requirements.

1. Recommend the use of AW32 or AW46 anti-wear hydraulic oil.
2. The hydraulic oil of the lifts should be replaced regularly during use. Replace the hydraulic oil 3 months after the first installation, Replace the hydraulic oil once a year afterwards.
3. Make at least one full trip raising and lowering per day. To bleed any air from the system, which could effectively avoid the corrosion of the cylinder and damage to the seals caused by presence of air or water in the system.

Protect the outer surface of the oil cylinder's piston rod from bumping and scratching, and clean any debris on the oil cylinder dust-ring and the piston rod as soon as possible.

## VIII. TROUBLE SHOOTING

TROUBLE	CAUSE	REMEDY
Motor does not run	<ol style="list-style-type: none"> <li>1. Start button does not work</li> <li>2. Wiring connections are not in good condition</li> <li>3. Motor burned out</li> <li>4. AC contactor in damage</li> </ol>	<ol style="list-style-type: none"> <li>1. Replace Start button</li> <li>2. Repair all wiring connections</li> <li>3. Repair or replace motor</li> <li>4. Replace or replace</li> </ol>
Motor runs but the lift is not raised	<ol style="list-style-type: none"> <li>1. Motor runs in reverse rotation</li> <li>2. Gear pump out of operation</li> <li>3. Release valve in damage</li> <li>4. Relief valve or check valve in damage</li> <li>5. Low oil level</li> </ol>	<ol style="list-style-type: none"> <li>1. Reverse two power wire</li> <li>2. Repair or replace</li> <li>3. Repair or replace</li> <li>4. Repair or replace</li> <li>5. Fill tank</li> </ol>
Lift does not stay up	<ol style="list-style-type: none"> <li>1. Release valve out of work</li> <li>2. Relief valve or check Valve leakage</li> <li>3. Cylinder or fittings leaks</li> </ol>	Repair or replace
Lift raises slowly	<ol style="list-style-type: none"> <li>1. Oil line is jammed</li> <li>2. Motor running on low voltage</li> <li>3. Oil mixed with air</li> <li>4. Gear Pump leaks</li> <li>5. Overload lifting</li> </ol>	<ol style="list-style-type: none"> <li>1. Clean the oil line</li> <li>2. Check electrical system</li> <li>3. Fill tank</li> <li>4. Replace pump</li> <li>5. Check load</li> </ol>
Lift cannot lower	<ol style="list-style-type: none"> <li>1. Safety device are locking.</li> <li>2. Release valve in damage</li> <li>3. Safety cable broken</li> <li>4. Oil system is jammed</li> </ol>	<ol style="list-style-type: none"> <li>1. Release the safeties</li> <li>2. Repair or replace</li> <li>3. Replace</li> <li>4. Clean the oil system</li> </ol>

# PREVENTIVE MAINTENANCE SCHEDULE

The periodic Preventive Maintenance Schedule given is the suggested minimum requirements and minimum intervals; accumulated hours or monthly period, whichever comes sooner.

Periodic maintenance is to be performed on a daily, weekly, and yearly basis as given in the following paragraphs. In the event you need replacement parts

## **WARNING!!**

The American National Standards Institute (ANSI) requires users to inspect lifting equipment at the start of every shift. These and other periodic inspections are the responsibility of the user.

Failure to perform the daily pre-operational check can result in expensive property damage, lost production time, serious personal injury, and even death. The safety latch system must be checked and working properly before the lift is put to use.

Failure to heed this warning can result in death or serious injury, or damage to equipment. If you hear a noise not associated with normal lift operation, or, if there is any indications of impending lift failure - CEASE OPERATION IMMEDIATELY! - Inspect, correct and/or replace parts as required.

### **Daily Pre-Operation Check (8-Hours)**

- Check safety lock audibly and visually while in operation
- Check safety latches for free movement and full engagement with rack.
- Check hydraulic connections, and hoses for leakage.
- Check cables connections bends, cracks-and for loose fittings.
- Check for frayed cables in both raised and lowered position.
- Check snap rings at all rollers and sheaves.
- Check bolts, nuts, and screws and tighten if needed.
- Check wiring & switches for damage.
- Check floor for stress cracks near columns.
- Check Lubrications on cable sheaves and shafts.

### **Weekly Maintenance (every 40-Hours)**

- IF LIFT IS ANCHORED TO FLOOR** - Check anchor bolts torque to **50 ft-lbs. (67.8nm)** for the  $\frac{3}{4}$  in (19mm). anchor bolts. Do not use an impact wrench to tighten anchor bolts.
- Check floor for stress cracks near columns
- Check hydraulic oil level.
- Check and tighten bolts, nuts, and screws.
- Check all cable sheaves/assembly for free movement or excessive wear on cable sheave shaft.

### **Yearly Maintenance**

- Lubricate the cable sheave shaft by using grease gun at least once a year after the lift is in service.
- Check for excessive wear of cable. Replace them if necessary.
- Change the hydraulic fluid - good maintenance procedure makes it mandatory to keep hydraulic fluid clean.
- No hard-fast rules can be established; - operating temperature, type of service, contamination levels, filtration, and chemical composition of fluid should be considered. If operating in dusty environment shorter interval may be required.

**Special Maintenance Tasks**

**NOTE:** The following items should only be performed by a trained maintenance expert:

Replacement of hydraulic hoses.

Replacement of cables and sheaves.

Replacement or rebuilding air and hydraulic cylinders as required.

Replacement or rebuilding pumps / motors as required.

Checking of hydraulic cylinder rod and rod end (threads) for deformation or damage.

**CAUTION**

**Relocating or changing components may cause problems. Each component in the system must be compatible; an undersized or restricted line will cause a drop in pressure. All valve, pump, and hose connections should be sealed and/or capped until just prior to use. Air hoses can be used to clean fittings and other components. However, the air supply must be filtered and dry to prevent contamination. Most important is cleanliness; Contamination is the most frequent cause of malfunction or failure of hydraulic equipment.**



# WARRANTY

Canadian Auto Equipment

T: 1-888-269-3346

E: [support@canadianautoequipment.ca](mailto:support@canadianautoequipment.ca)

[www.canadianautoequipment.ca](http://www.canadianautoequipment.ca)

## Warranty (Limited)

Canadian Auto Equipment warrants its 2 post lifts for 5 years on structural components, 1 year on hydraulic power units and cylinders and wear items such as cables, sheaves, sliders, plastic and rubber components for 90 days from invoice date. This Warranty (Limited) shall not apply unless the product is installed, operated, used and maintained in accordance with specifications set forth in the Installation / Maintenance / Owner's Manual. Voiding of this warranty also include: user neglect or abuse, improper lifting or overloading, alteration of the original design, improper repairs, exposure and damage by any corrosion, any cosmetic defects or blemishes that do not interfere with functionality of the lift including any damaged to components incurred during transportation or unloading.

Our Warranty (Limited) does not include a labor warranty or free shipping on any parts as these products are sold at very competitive prices and we simply can't afford to send technicians to your location. We will however support you over the phone and can assist via Facetime or Skype at your convenience. We can also recommend service technicians that may be in your region that can offer assistance and perhaps offer a house call at the customers expense. This warranty is applicable to the original purchaser only and is not transferable.

All Warranty (Limited) claims must be approved by the manufacturer to be valid. Canadian Auto Equipment shall replace those parts which will be returned by the customer to a said Canadian warehouse at the customers expense.

Subject to the conditions of our Warranty (Limited), if the goods fail to operate for any reason within the applicable warranty period, we will repair or replace the goods free of charge. Please note that our Warranty (Limited) does not include a labor warranty or free shipping on any parts.

Products may not be returned without any prior written approval from Canadian Auto Equipment.

## Warranty Information Section - Complete this section for your records

Type of Lift: \_\_\_\_\_

Date of purchase: \_\_\_\_\_

Invoice Number: \_\_\_\_\_

Model Number: \_\_\_\_\_

Serial Number: \_\_\_\_\_

Name on Invoice: \_\_\_\_\_